



## **FCS-6020**

**PT Network Camera, 2-Megapixel,  
Say & Night, PoE 802.3af, IR LEDs,**

# **User Manual**

Version 1.0

# Table of Contents

Overview.....3  
 Package Contents.....4  
 Hardware Description .....5  
 Hardware Installation .....7  
 Connect to the Network Camera..... 10  
     Install the IP Finder program..... 10  
     Bonjour program ..... 17  
     C2.mylevel1.com(Free DDNS service) ..... 18  
 Initial Access to the Network Camera ..... 19  
 Primary user's capability .....20  
     Main Screen with Camera View .....20  
     Client Setting .....23  
 Definitions in Configuration .....25  
     System parameters.....25  
     User Management .....27  
     Network .....29  
     Access list.....33  
     Audio and Video setting .....34  
     Video record .....36  
     Stream .....38  
     Camera control .....40  
     Application .....42  
     Storage .....45  
     Syslog.....46  
     Status and Parameters .....47  
     Maintenance .....48  
 Appendix.....50  
     A. Troubleshooting & Frequently Asked Questions .....50  
     B. Technical specifications .....55

## Default Settings

<b>IP Address</b>	DHCP
<b>Username</b>	root
<b>Password</b>	

## Overview

The LevelOne FCS-6020 is a quality yet cost-effective surveillance solution for the home and office. It is designed for easy and flexible installation, supporting two power options (12 VDC/PoE) and the motorized Pan and Tilt provides a viewing angle of  $\pm 355^\circ$  pan and  $\pm 135^\circ$  tilt. Equipped with a 2-Megapixel sensor and built-in IR cut filter/IR illuminator LEDs, the camera provides high resolution quality and sharp sensitivity – ideal for security applications both day and night.

The FCS-6020 is equipped with many advanced features such as Level1DNS™ Service, DI/DO for external alarm and sensor, a SD/SDHC card slot and USB interface for local storage, built-in microphone and external speaker for 2-way audio communications. Moreover, users can also set up 16 motion-detection regions with the camera, each with adjustable size and sensitivity. When motion is detected at the specified regions, the system can send an E-mail alert or send captured images via FTP upload to a designated storage server. The FCS-6020 is indisputably the top choice for reliable and high performance surveillance.

Law in your country may prohibit the use of surveillance devices. The Network Camera is not only a high-performance web-ready camera but also can be part of a flexible surveillance system. It is the user's responsibility to ensure that the operation of such devices is legal before installing this unit for its intended use.

### Minimum System Requirement

<b>Personal Computer</b>	<ul style="list-style-type: none"> <li>· CPU: Intel® Celeron® Dual-Core @2.70GHz or above</li> <li>· Memory Size: 2 GB or above recommended</li> <li>· VGA card resolution: 1024 x 768 or above</li> </ul>
<b>Operating System</b>	<ul style="list-style-type: none"> <li>· Windows XP/ Windows 7</li> </ul>
<b>Web Browser</b>	<ul style="list-style-type: none"> <li>· Microsoft Internet Explorer 6.0 or later</li> <li>· Firefox</li> <li>· Chrome</li> </ul>
<b>Network Card</b>	<ul style="list-style-type: none"> <li>· 10Base-T (10 Mbps) or 100Base-TX (100 Mbps) operation</li> </ul>
<b>Viewer</b>	<ul style="list-style-type: none"> <li>· ActiveX control plug-in for Microsoft IE</li> </ul>

## ***Package Contents***

- Network Camera
- Power Adapter
- Camera Stand
- LAN Cable
- Quick Installation Guide
- CD Manual / Utility

If any of the above items are missing, please contact your dealer immediately.

**Note:** *Using a power supply with a different voltage than the one included with the Network Camera may cause damage and void the warranty for this product.*

## Hardware Description



- 1. Auto Light Sensor
- 2. IR LEDs
- 3. Built-in Mic
- 4. Status LEDs

- 5. Ethernet
- 6. DI/DO
- 7. Line Output
- 8. SD/SDHC Card Slot

- 9. Mic/line Input
- 10. DC Power Jack
- 11. USB Port

### 1. Light Sensor

Automatically detects lighting condition to turn IR LEDs on/off.

### 2. Infrared LEDs

There are twelve Infrared (IR) LEDs in front of camera for night vision purpose. The IR LEDs will auto or manual turn on when the camera is in the dark environment.

### 3. Built-in Microphone

The camera has a built-in internal microphone. This microphone is hidden in the pinhole located on the head of camera.

### 4. Front LEDs

Red LED indicates power, red LED will turn on always after plug-in power. Green LED indicates networking, green LED will blink every second after getting IP address.

Upon powering up, two of front LEDs will become lighted then the camera will do self-rotation. During the self-rotation, red LED will be on and the network camera is standing by for getting an IP address.

### 5. Ethernet Port

Beside the DC power Jack, the LAN socket is an RJ-45 connector for connections to 10Base-T or 100Base-TX Fast Ethernet cabling. Please use a Cat 5 “straight through” cable to connect the Network Camera to an Ethernet network switch or hub.

**6. General I/O Terminal Block**

Used for connecting to external input/output devices like alarms or sensors.

**7. Line Output**

The Network Camera supports two way audio communication so that operators can transmit and receive audio simultaneously. By using the Network Camera's built-in or external microphone and an external speaker, you can communicate with people around the Network Camera.

**8. SD/SDHC Card Slot**

The SD/SDHC card slot offers a convenient and portable storage (snapshots and video clips) option to prevent data loss in case of network disconnection.

**9. Microphone/Line In**

The Network Camera supports two way audio communication so that operators can transmit and receive audio simultaneously. By using the Network Camera's built-in or external microphone and an external speaker, you can communicate with people around the Network Camera.

**10. DC Power Jack**

The input power is 12VDC. Note that supply the power to the Network Camera with standard power adapter included in package. Otherwise, the improper power adapter may damage the unit and result in danger.

**11. USB Port**

The USB slot offers a convenient and portable storage (snapshots and video clips) option to prevent data loss in case of network disconnection.

## Hardware Installation

### 1. Attach the Network Camera with the included stand

### 2. Place the Camera on the table or fix it onto ceiling or wall

Use screws to fix the Network Camera onto the ceiling or wall. You could also place the Network Camera on the table directly.

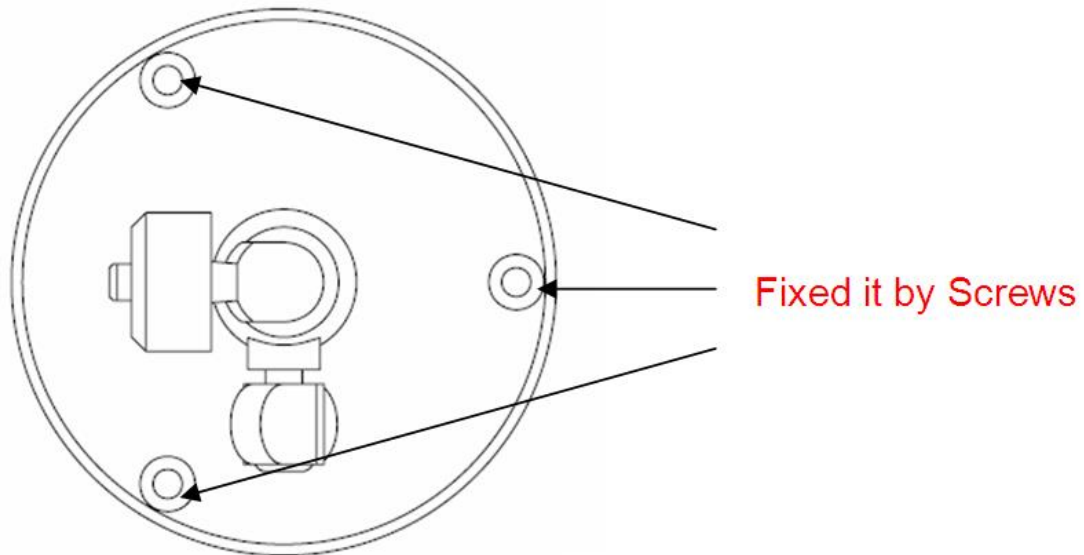

### 3. Plug a RJ-45 Ethernet cable into the Network Camera

Connect an Ethernet cable to the LAN socket located on the rear of network camera and connect it to a network.

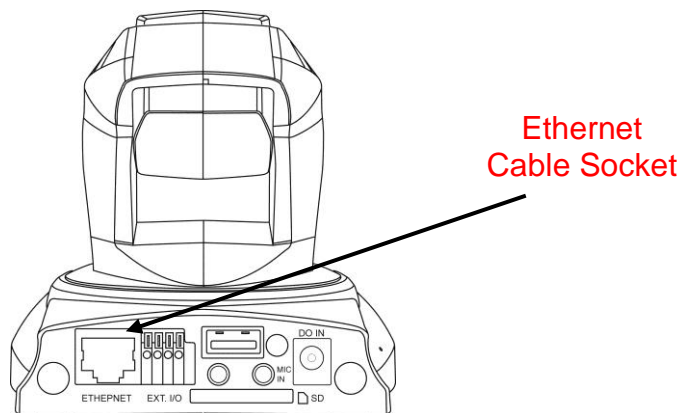

#### 4. Connect the external power supply to the network camera

Connect the attached power adapter to the DC power jack of the Network Camera. **Note:** Use the power adapter, 12VDC, included in the package and connect it to wall outlet for AC power.

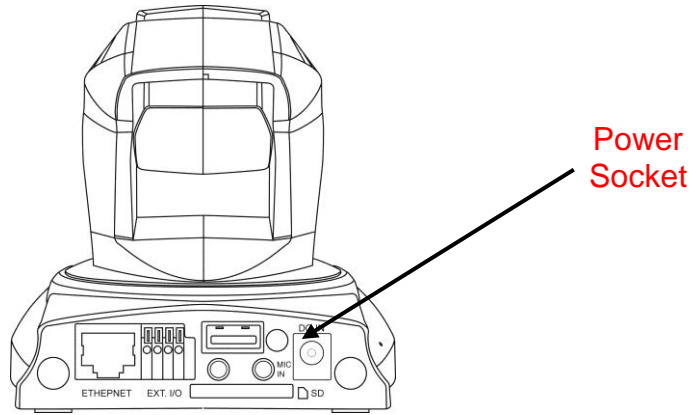

Once you have installed the Network Camera well and powered on, the camera will do self-rotation and then the red LED will turn on and green LED will flash every second. It means that the system is booting

#### 5. General I/O Terminal Block

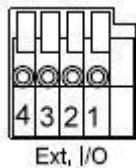

- 1: Power
- 2: Digital output
- 3: Digital input
- 4: Ground

Pin	Name	Specification	Remarks
1	Power	12VDC $\pm$ 5%, max. 1.5A	Max. rating 2A
2	Digital output	Max. 40VDC, max. 400mA, isolation 2kV	
3	Digital input	OPEN/Short-to-GND, isolation 2kV	Internal pull-up
4	Ground		

If you have external devices such as sensors and alarms, connect it to the I/O terminal block.



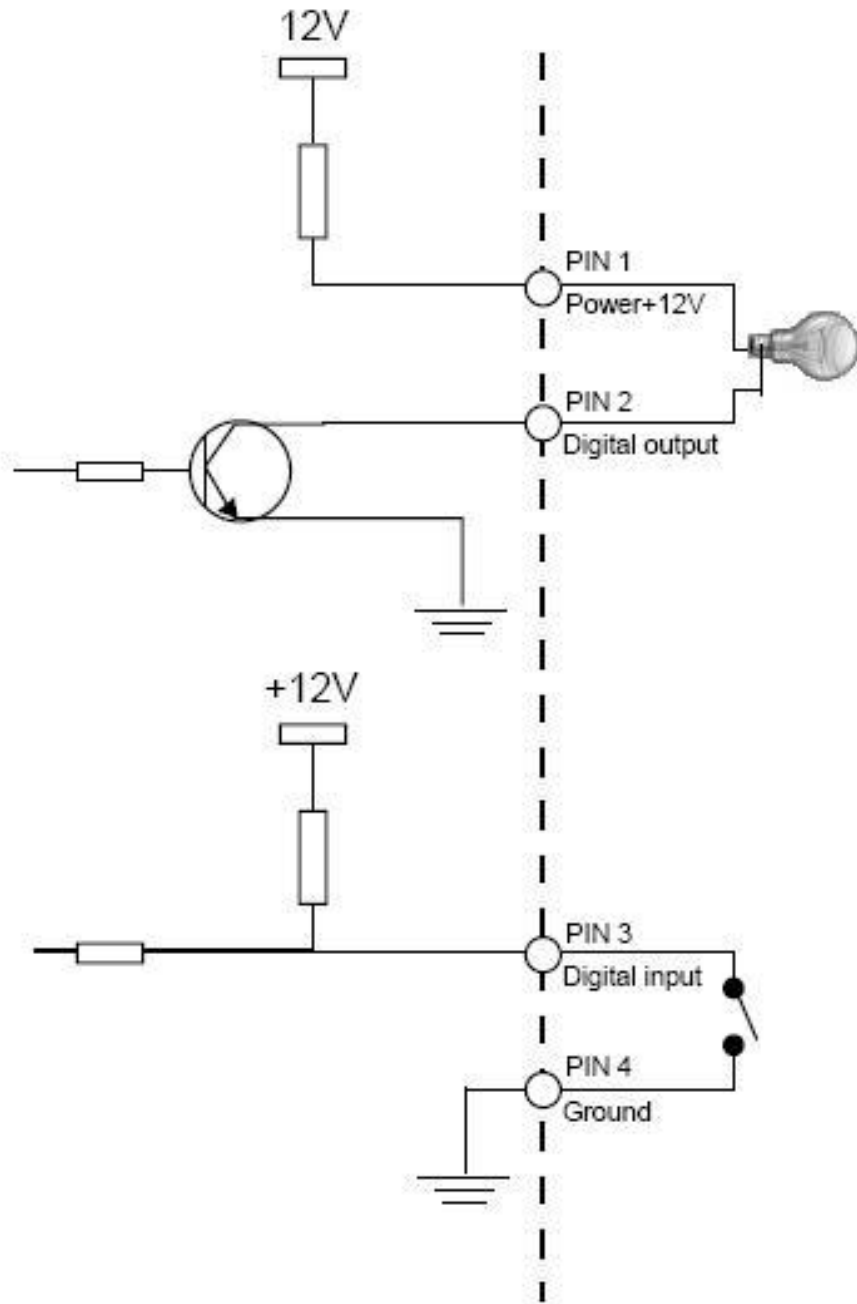

## ***Connect to the Network Camera***

### **Install the IP Finder program**

When you installed your Network camera on your LAN environment, you may install “IP Finder” to discover Network camera’s IP address. The Administrator must place the product software CD into the CD-ROM drive of the PC running in Microsoft Windows. An auto-run program will pop up (If the program is not on auto-run, go to the root directory of the software CD and click on “autorun.exe”).



Click on “Software Utility” item, after the window contents changed, click on “Install IP Finder” to run “IP Finder” program.



“IP Finder” is used to search the IP address of Network Cameras or Video servers on a LAN. After searching, Video Servers or Network Cameras will be located by the IP Finder.

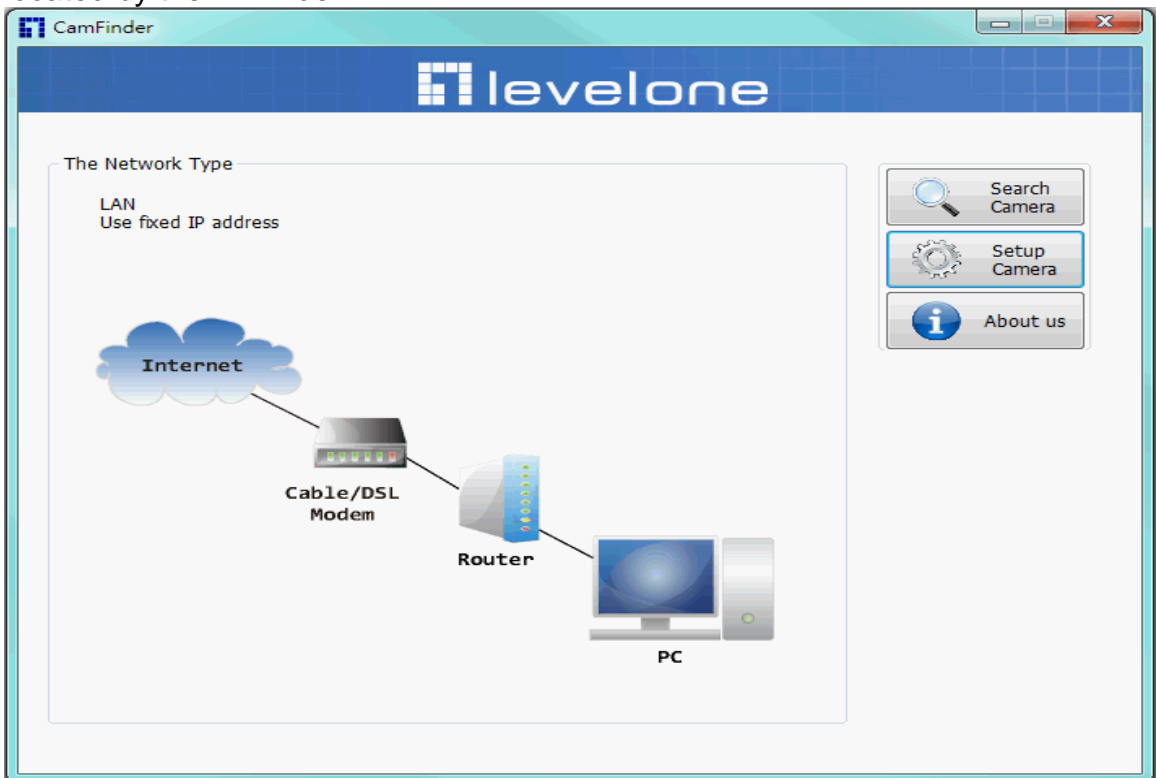

## Search Camera

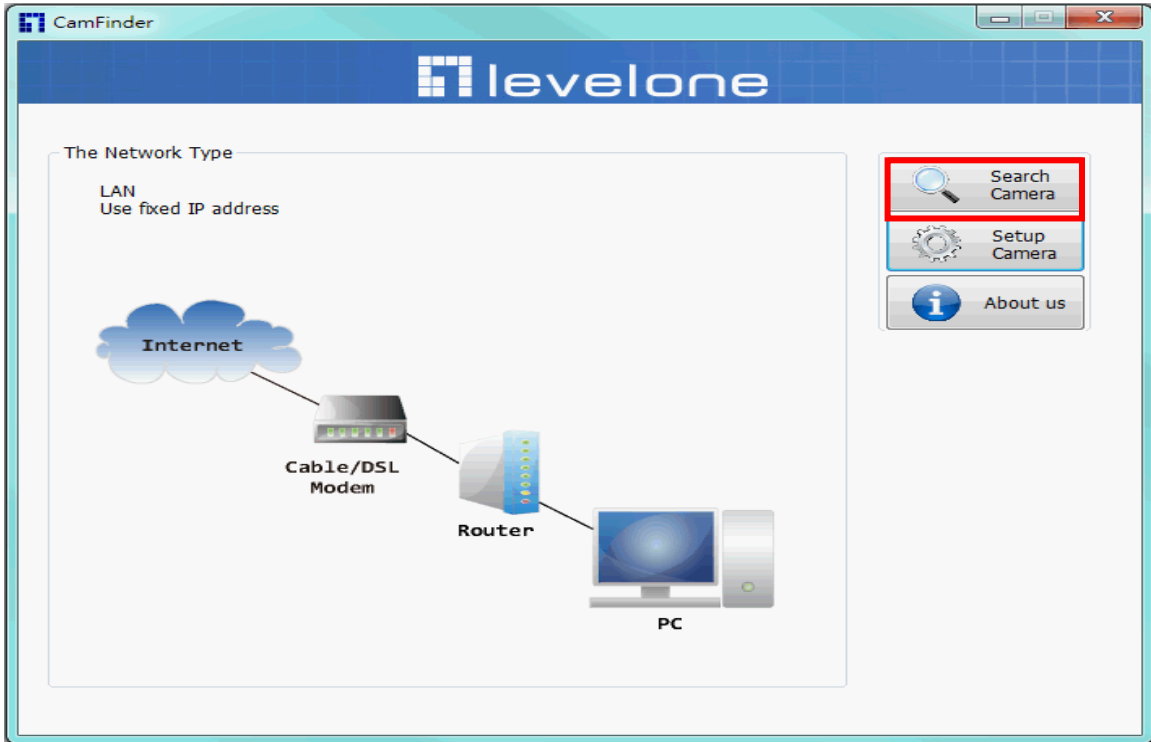

Click search Camera button, The program will search for all family network devices on the same LAN. After searching, the main installer window will pop up. Click on the MAC and model name which matches the product label on your device to connect to the Network Camera via Internet Explorer.



## Setup Camera

Auto Install Wizard will be started and that it can auto guide through the installation process. Press the “**Next**” button execute next process. For more information, please refer to the Network section on page 33.

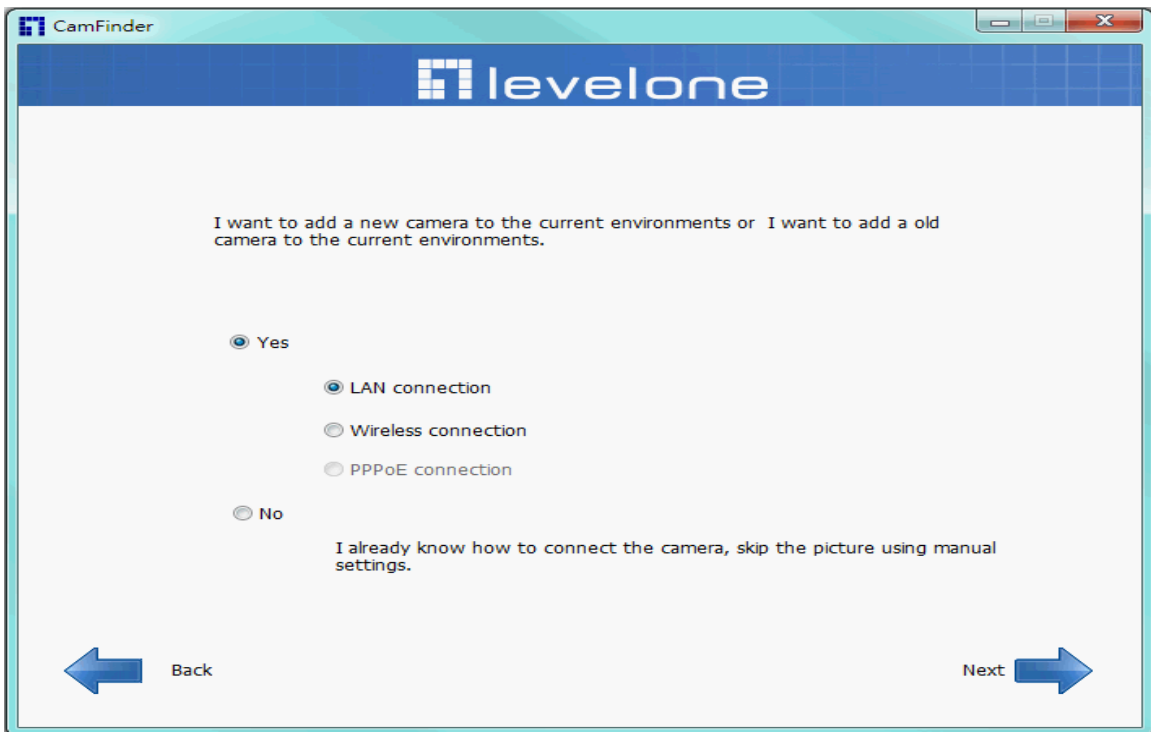
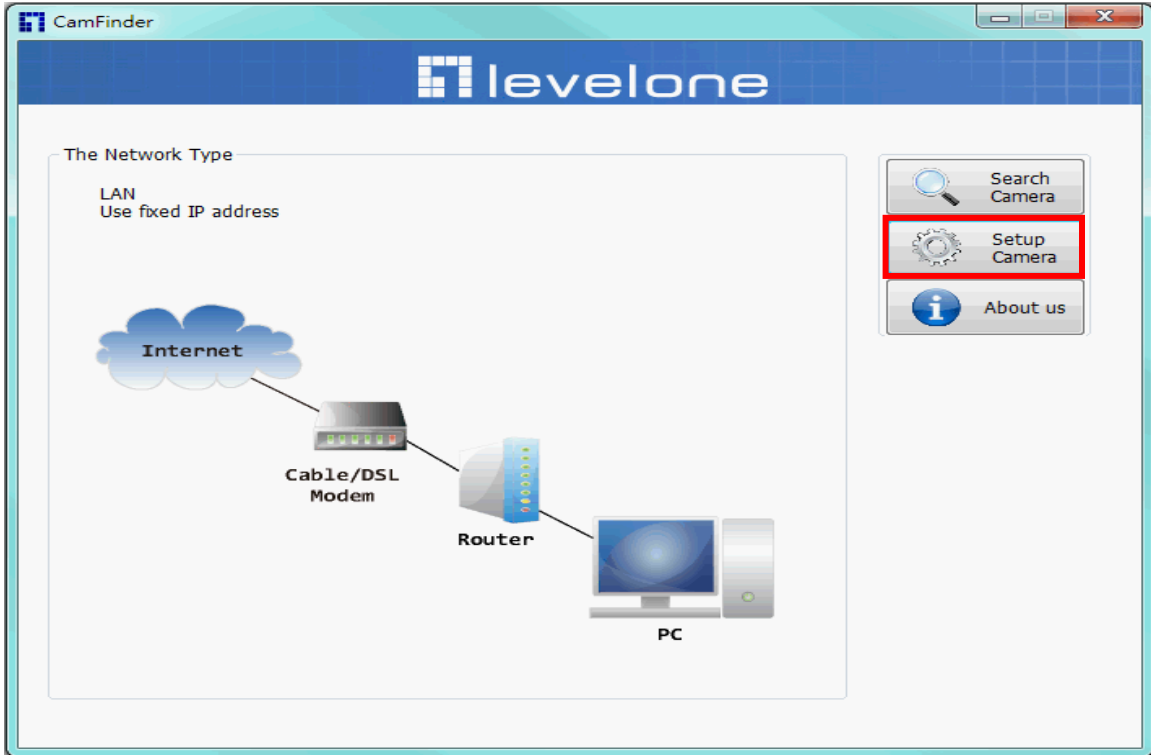

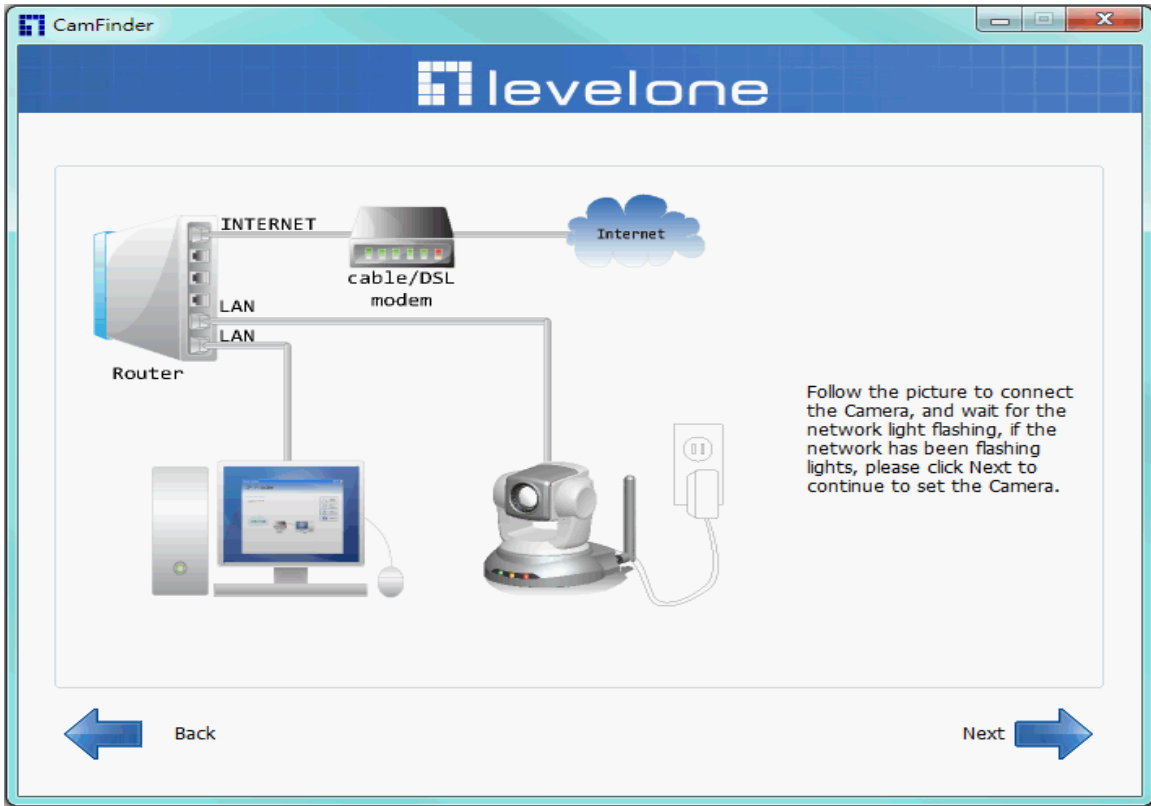

The screenshot shows the CamFinder software interface. At the top, there is a "levelone" logo. Below the logo, there is a "Camera List" section with a "Start Find" button. The camera list contains one entry:

IP	MAC	PORT	DESC / INTERFACE	SPORT
192.168.0.99	00:11:68:00:81:E1	80	FCS-6020/ethernet	54

Below the table, there is a text instruction: "Please use the search button in the upper right and select the camera, press Next to continue configuring the camera." At the bottom, there are "Back" and "Next" navigation buttons.

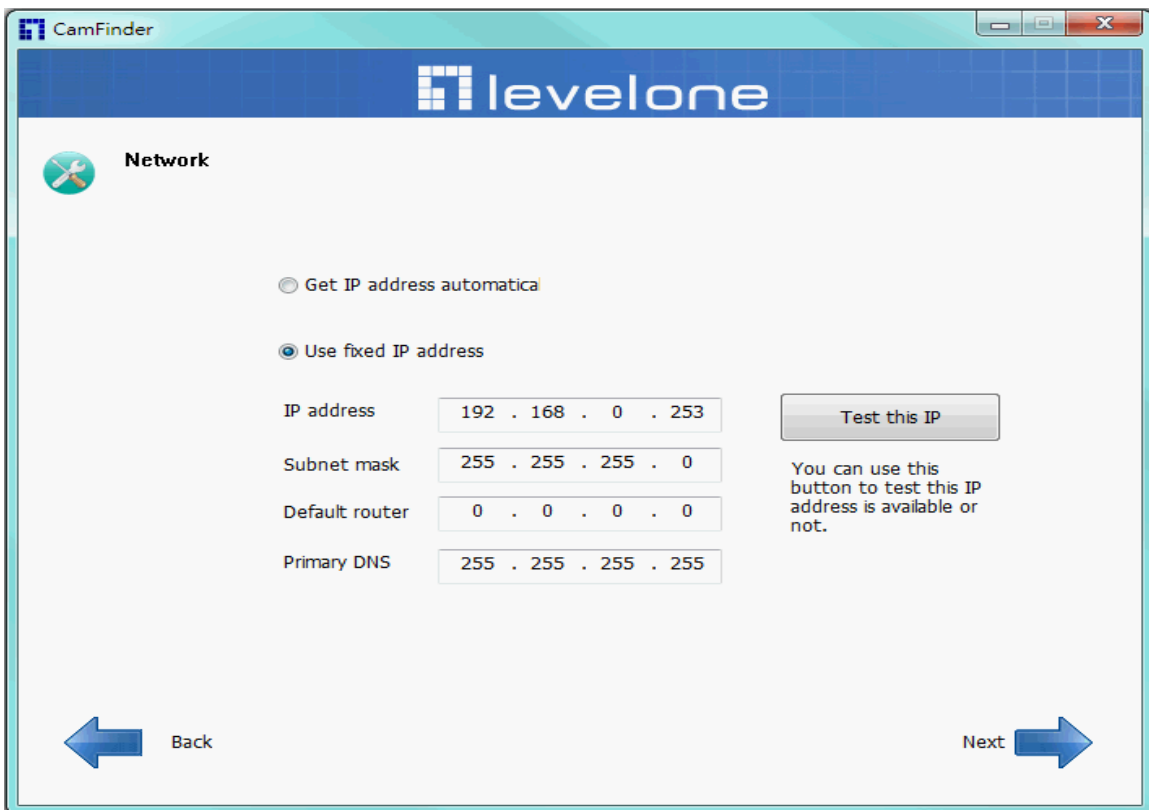
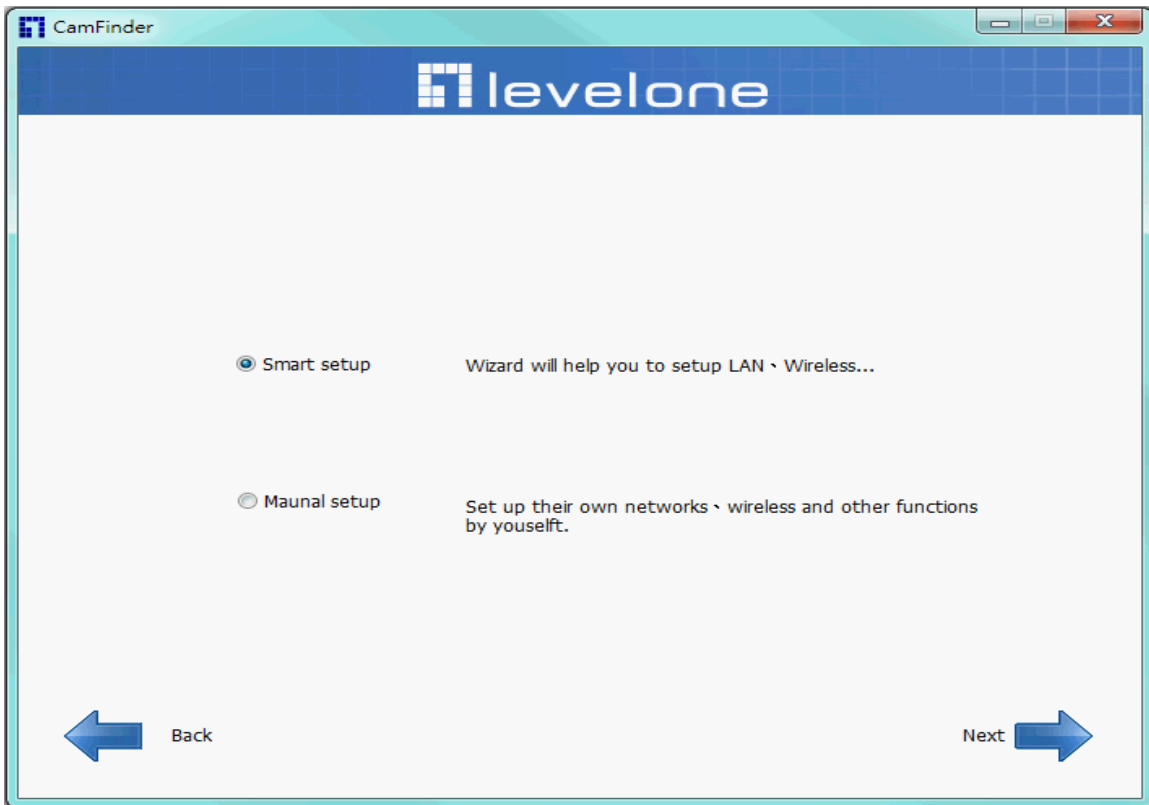

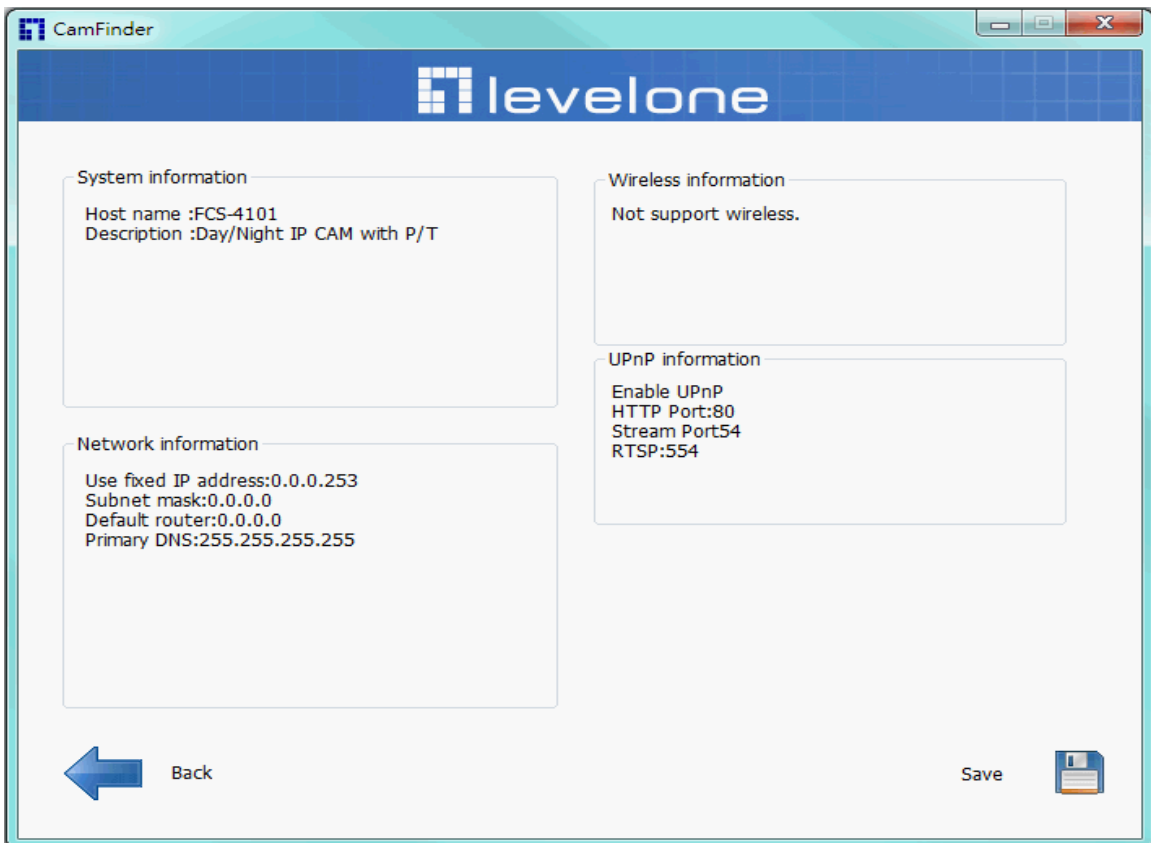
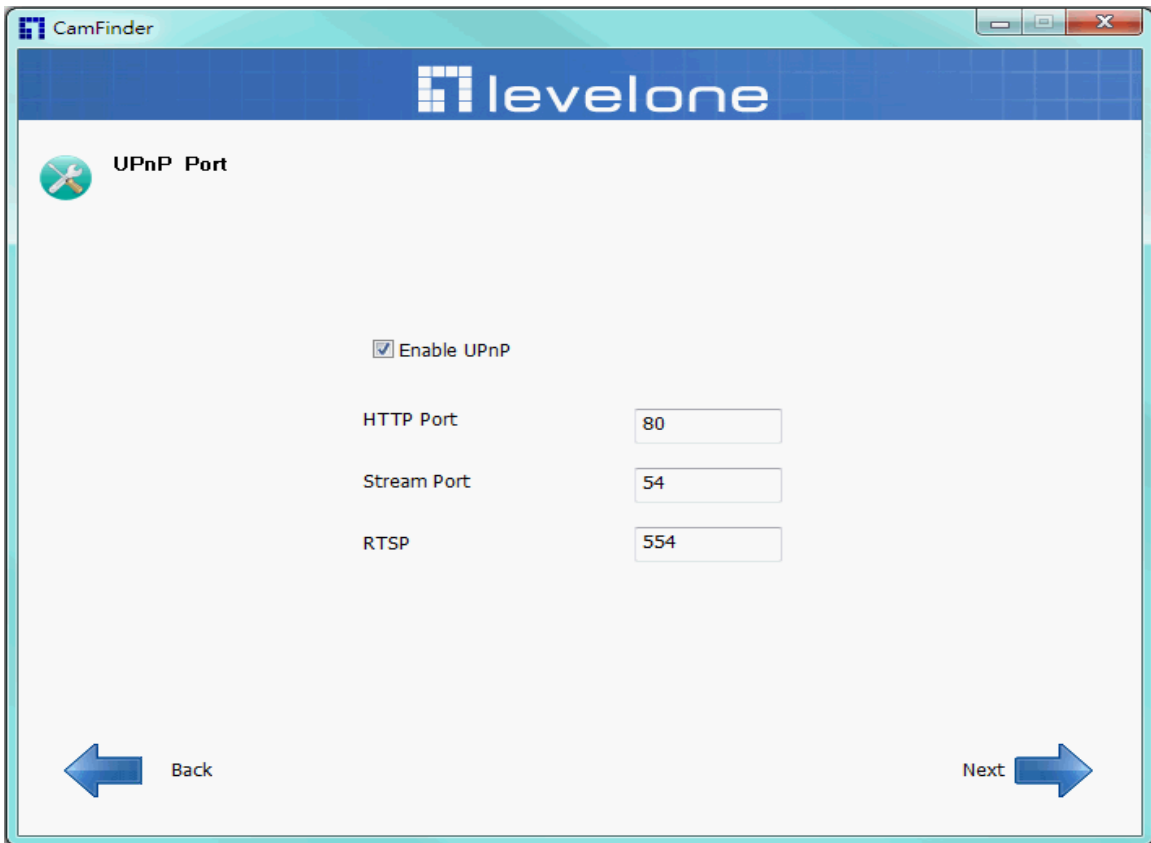



## Bonjour program

Safari browser supports Bonjour search program the will search for all family network devices on the same LAN.

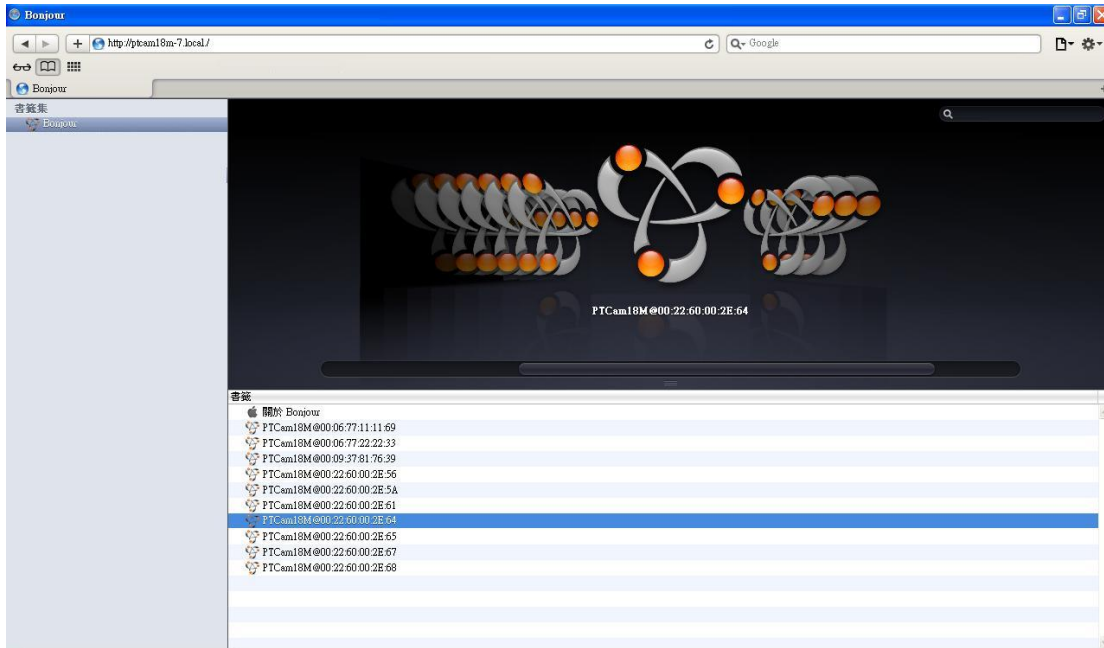

## C2.mylevel1.com(Free DDNS service)

1. When you want to connect the network camera over Internet, you can use the service “**C2.mylevel1.com**”. The “ip-discovery.com” is a free DDNS server for this camera. Make sure that the router must start UPnP and DHCP server functions. You can get the domain name which you wish very easily after registration. In Network page—DDNS settings of this camera, you just input the host name you want and your e-mail address, and click “Register”, then you can have the hostname for this camera not longer than 20 seconds if the DDNS registration result is OK. Then you can connect to this ip camera by

\*<http://XXX.c2.mylevel1.com:@@@@>

\*XXX: the host name you type

\*@@@@: The HTTP port (get it automatically by c2.mylevel1 server)

**DDNS setting**

Please input the C2.mylevel1.com DDNS parameters

Host name  .C2.mylevel1.com

E-mail

The following port numbers is needed to set up at your router's mapping table by yourself. Change the port values if needed. Make sure the values must be the same as that set up at your router's mapping table.

HTTP port

HTTPS port

RTSP port

Video RTP port

Video RTCP port

Audio RTP port

Audio RTCP port

User password: Default the password is last six number of the MAC. To change “root” password at “Security configuration” can change the user password, This “User password” is entered in the c2.mylevel1.com Password.

Note: You must set the ports between your router and camera manually if the registration is failed.

## ***Initial Access to the Network Camera***

- (1) For the initial access to the Network Camera in Windows, the web browser may prompt for permission to install a new plug-in for the Network Camera. This plug-in has been registered for certificate and is used to display the video in the browser. Users may click on  to proceed.

**1. Click “Install” and “Run” ActiveX controls**

**2.The video will be displayed.**



## Primary user's capability

### Main Screen with Camera View

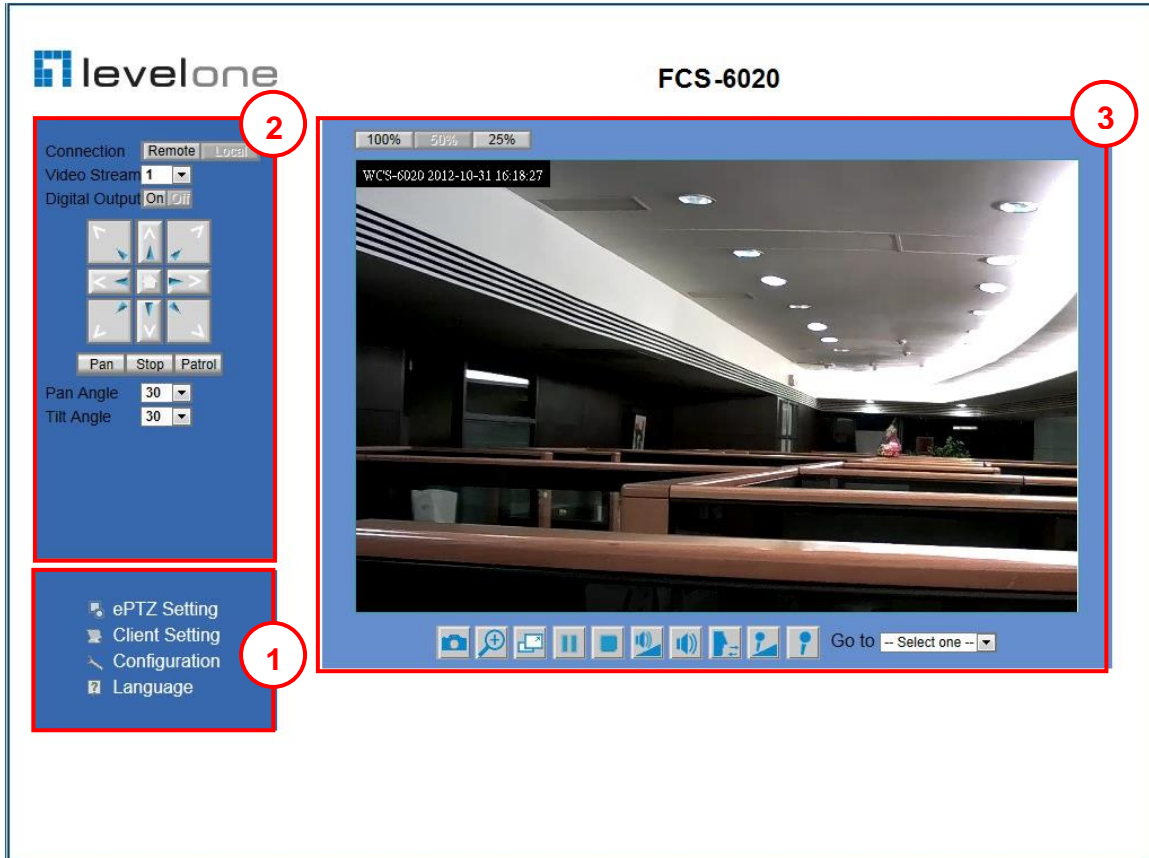

The main page has three parts:

- 1. Configuration functions:** The camera can be configured using these user interfaces.
- 2. Pan/Tilt & connection control buttons:** These buttons provide the direction to control the pan and tile of camera.
- 3. Camera View:** What the camera sees.

#### Configuration functions:

**ePTZ Settings:** Electronic pan/tilt/zoom capabilities that enable users to move to a target region instantly for close-up shots by simply clicking on the video feeds on their screen rather than moving the camera physically.











**Client Settings:** Clicking on this button links you to the client setting page.

**Configuration:** Please note that only the administrator can access it.

**Language:** Click this button to choose a language for the user interface.

**Note:** ePTZ function is only available under image size of 1280x800

## Camera View:

1.  Click this button to capture and save still images. The captured images will be displayed in a pop-up window. Right-click the image and choose "Save Picture As" to save it in JPEG format.
2.  This button lets you open a digital zoom, and to control the window to enlarge a specified area in the camera view.
3.  Click this button to switch to full screen mode. Press the "Esc" key to switch back to normal mode.
4.   Click on this button to pause/play the video.
5.  Click on this button stop video output.
6.  Click on this button to adjust the audio volume.
7.  Click on this button to toggle mute On/Off.
8.  Click on this button to toggle 2-way audio on/off. Enabling this function requires an external speaker connected. The server can play sound from the client and receive sound from the environment and send to client.
9.  Once the Administrator has determined the preset positions; the User can aim the camera using this control.

## Pan/Tilt & connection control buttons:

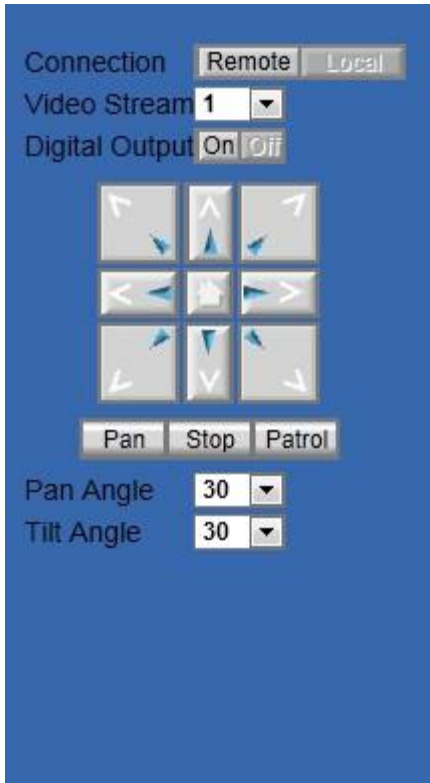

- 1. Connection:** User can choose Remote or Local mode for best connection quality.
- 2. Video Stream:** User can choose stream1 or stream2.
- 3. Digital Output:** Clicking on the “On” or “Off” button turns the digital output to either on or off status.
- 4. Control Buttons:** “Left”, “Right”, “Up”, “Down”, “Cross Angles”, and “Home”. Camera returns to center when click “Home” button
- 5. Pan Angle:** User can choose the angles when the camera moves left and right each time.
- 6. Tilt Angle:** User can choose the angles when the camera moves up and down each time.
- 7. Pan:** The camera will move from right side to left side continuously when click the button.
- 8. Stop:** User can stop the movement of camera, such as Auto pan, Auto Patrol, and etc., by clicking the button.
- 9. Patrol:** The button directs the camera to patrol among the preset positions in the patrol list, which can be modified on the “**Camera control**

page”. The cycle of patrol is from 1 to 5.

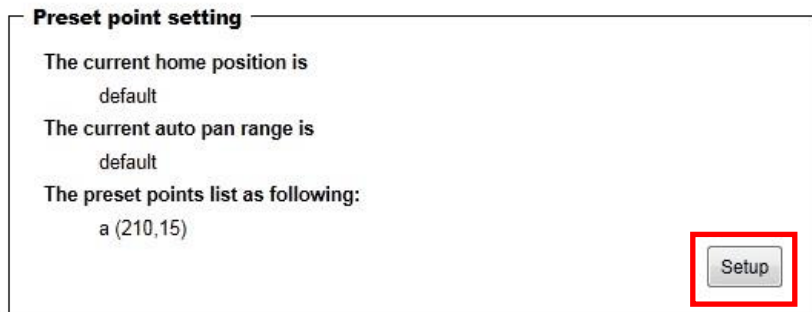
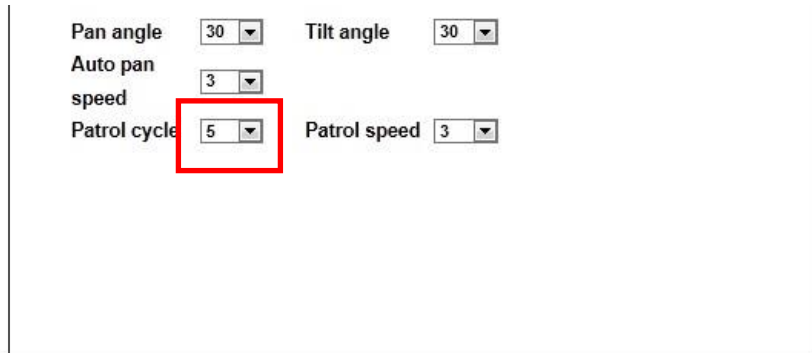

## Client Setting

The screenshot shows the 'Client setting' web interface for a Levelone network camera. The interface has a blue header with the Levelone logo and the text 'Client setting 1.1.2.14'. On the left, there is a navigation menu with a 'Home' button. The main content area is divided into three sections, each with a title and a list of radio button options:

- Video output setting:** Options are 'stream' (selected) and 'picture'.
- Internet setting:** Options are 'UDP', 'TCP', and 'HTTP' (selected).
- Intranet setting:** Options are 'UDP' (selected), 'TCP', and 'HTTP'.

- 1. Video output setting:** Set video output format.
  - **Stream:** Select use multiple stream video.
  - **Picture:** Select use serial video picture.
- 2. Internet Protocol Options:** Set internet protocol.
  - **UDP:** Select to use UDP protocol.
  - **TCP:** Select to use TCP protocol.
  - **HTTP:** Select to use HTTP protocol.
- 3. Intranet Protocol Options:** Set intranet protocol.
  - **UDP:** Select to use UDP protocol.
  - **TCP:** Select to use TCP protocol.
  - **HTTP:** Select to use HTTP protocol.

**NOTE :** Protocol options allow choices on the connection protocol between client and server. There are three protocols choices to optimize your usage – UDP, TCP, HTTP.

The **UDP** protocol allows for more real-time audio and video streams. However, some packets may be lost due to network burst traffic and images may be obscured.

The **HTTP** protocol allows for less packet loss and produces a more accurate video display. The downside with this protocol is that the real-time effect is worse than that with the UDP protocol.

The **TCP** guarantees the complete delivery of streaming data and thus provides better video quality. However, the real-time effect is not as good as that of the UDP protocol.

If no special need is required, UDP protocol is recommended. Generally speaking, the client choice will be in the order of UDP → HTTP. After the Network Camera is connected successfully, "Protocol Option" will indicate the selected protocol. The selected protocol will be recorded in the user's PC and will be used for the next connection. If the network environment is changed, or the user wants to let the web browser to detect again, manually select the UDP and TCP protocol, save, and return HOME to re-connect.



## Definitions in Configuration

Please note that only the Administrator can access the system configuration. Each category in the left column will be explained on the following pages.

### System parameters

The screenshot displays the Levelone web interface for system configuration. The top header features the Levelone logo and the system version '1.1.2.14', which is highlighted with a red box and labeled 'Firmware version'. A left-hand navigation menu lists various settings categories. The main content area is divided into three sections: 'General setting', 'Time setting', and 'DI and DO setting'. Each section contains specific configuration options and a 'Setup' button.

Category	Parameter	Value
General setting	Host name	FCS-6020
	Led indicator	Turn on
Time setting	Time zone	(GMT+08:00) Beijing Chongqing, Hong Hong, Kuala Lumpur, Singapore, Taipei
	Daylight saving time	Disable
	Current Time	2012/10/31 18:16:54
DI and DO setting	Digital input	
	The active state is	"high level"
	The current state detected is	"high level"
	Digital output	
The active state is	"grounded"	
The current state detected is	"open"	

#### 1. General Setting

##### (1) Host name

The text displays the title on the top of the main page.

##### (2) LED indicator

Select turn on or turn off the led indicator.

## 2. Time Setting

### (1) Time zone

Choose a time zone from the pull down menu.

### (2) Daylight saving

Enable or disable daylight saving time.

### (3) Current Time

Set the time of the network camera.

#### (A) Keep current date time

Click on this to keep the current date and time of the network camera. An internal real-time clock maintains the date and time even when the power of the system is turned off.

#### (B) Sync with PC

Synchronize the date/ time of the network camera with the local computer.

#### (C) Manually set the time

Adjust the date and time manually.

#### (D) Adjust by NTP server

Synchronize the time according to NTP server over the Internet whenever the Network Camera is switched on. It fails if the assigned time-server cannot be found.

**(a) NTP server:** Assign the IP address or domain name of the time-server. Leaving the text box blank connects the Network Camera to the default time server.

**(b) Update interval:** Select 0 ~ 23 hours update with the time on the NTP server.

## 3. DI and Do Setting

Select **Open** or **Ground** to define the DO active state.

Remember to click on ***“Finish”*** to immediately validate the changes. Otherwise, the correct time will not be synchronized.

# User Management



## Security setting

The administrator account name is “root”, which is permanent and can not be deleted. If you want to add more accounts in the Manage User column, please set a password for the “root” account first. The network camera can provide up to twenty accounts.

### 1. Change root password:

Change the Administrator’s password by typing in the new password identically in both text boxes. The typed entries will be displayed as asterisks for security purposes. After pressing “*finish*”, the web browser will ask the Administrator for the new password to access.

### 2. Manage privilege

You can modify the manage privilege of operators or viewers. Check or uncheck the item, then click **finish** to enable the settings.

### 3. Manage user

**(1) Add a new user:** Administrators can add up to 20 user accounts.

(A) Input the new user's name and password.

(B) Select the privilege level for the new user account. Click **Finish** to enable the setting.

**(2) Delete a user:** Select an existing user name. Click **Finish** to enable the setting.

**(3) Update a existing user:** Select an existing user name. Administrators can modify user's password and privilege. Click **Finish** to enable the setting.

Access rights are sorted by user privilege (Administrator, Operator, and Viewer). Only administrators can access the Configuration page. Operators cannot access the Configuration page but can use the URL Commands to get and set the value of parameters. Viewers access only the main page for live viewing.

# Network

Any changes made on this page will restart the system in order to validate the changes. Make sure every field is entered correctly before clicking on **“Finish”**

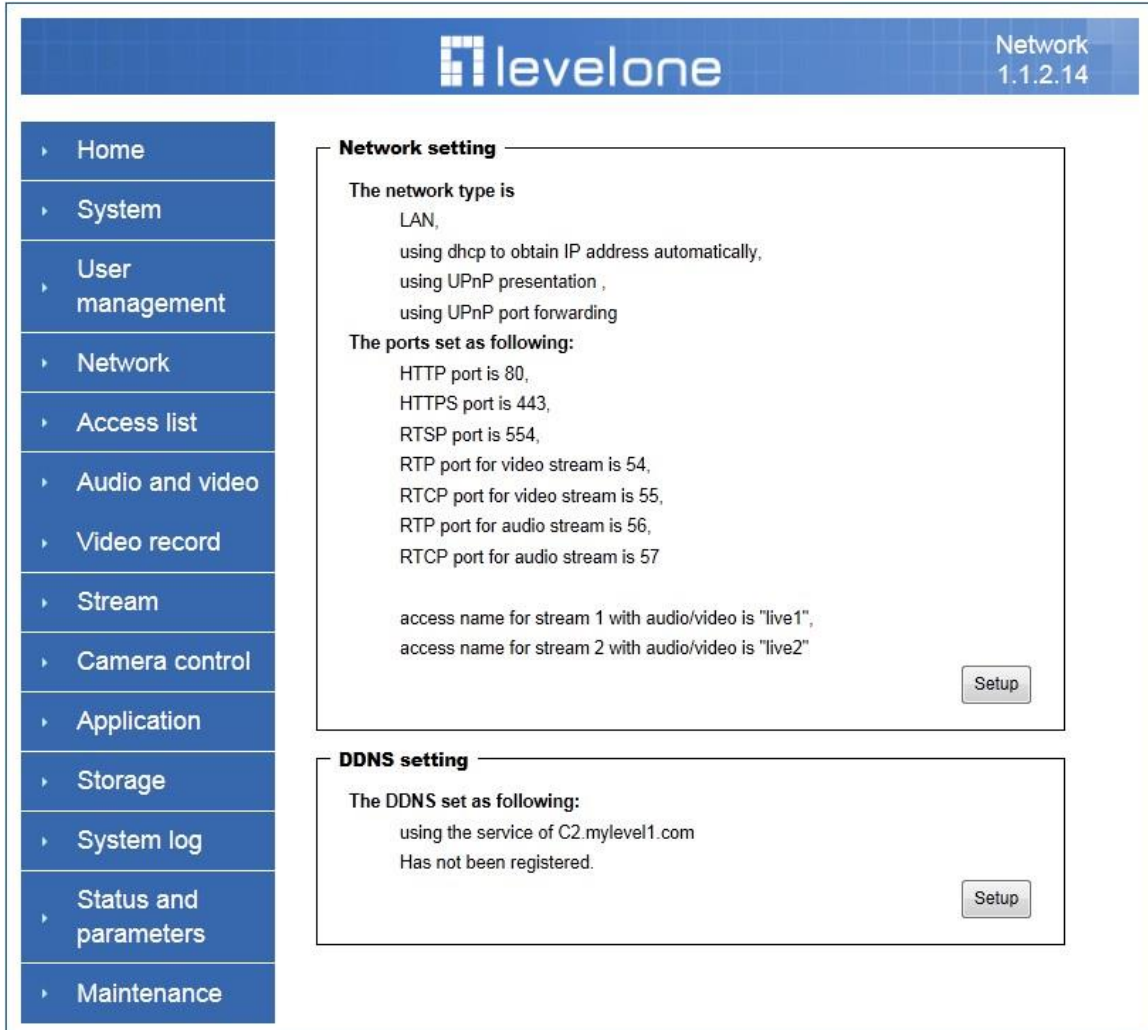

## Network Setting LAN / PPPoE

The default setting is LAN. Select PPPoE if using ADSL dialup.

### 1. LAN

The default status is **Get IP address automatically**. This could be tedious to perform software installation whenever the Network Camera starts. Therefore, once the network is set, the IP address should be entered correctly. Select **Use fixed IP address** then the Network Camera will skip installation. The Network Camera will automatically restart and operate normally after a power outage. You can run CamFinder to check the IP address assigned to the Network Camera if the IP address is forgotten, or you can use the UPnP function provided by the Network Camera.

**(1) Get IP address automatically**

**(2) Use fixed IP address**

- **IP address:** This is necessary for network identification.
- **Subnet mask:** This is used to determine if the destination is in the same subnet. The default value is "255.255.255.0".
- **Default router:** This is a gateway used to forward frames to destinations in a different subnet. Invalid router setting will fail the transmission to destinations in different subnet.
- **Primary DNS:** The primary domain name server that translates hostnames into IP addresses.
- **Secondary DNS:** Secondary domain name server backups the Primary DNS.
- **Enable UPnP presentation & port forwarding:** Enable UPnP function.
- **Http port:** This can be typed besides the default Port 80. Once the port is changed, users must make sure the change for the connection is successful. For instance, when the Administrator changes the HTTP port of the Network Camera which IP address is 192.168.0.20 from 80 or 1025 to 65535, the users must type in the web browser "http://192.168.0.20:8080" instead of http://192.168.0.20.
- **RTSP Port:** RTSP port can be typed besides the default Port 554.
- **RTP Port:** The RTP port can be typed besides the default Port 54.  
Note: Please set Video RTP port in even number after default value port 54. Then, Video RTCP port, Audio RTP port 、Audio RTCP port will automatically set the values in ascending.
- **RTSP Streaming access names:** The RTSP streaming currently supports video only, audio only, and audio/video. To use the audio/video stream, type the URL as "rtsp://61.30.125.43/liveN.sdp".

**2. PPPoE**

If using the PPPoE interface, you should fill the following settings from ISP.

- (1) User name:** The login name of PPPoE account
- (2) Password:** The password of PPPoE account
- (3) Confirm password:** Input password again for confirmation

**3. WIRELESS LAN (Wireless Model Only)**

**SSID** (Service Set Identifier), it is to identify a wireless network. Access Points and wireless clients attempting to connect to a specific WLAN (Wireless Local Area Network) must use the same SSID. The default setting is *default*. **Note:** *The maximum length of SSID is 32 single-byte characters and SSID can't be any of " , < , > and space character.*

**Wireless mode** Click the down arrow to select one from options

- 1. Infrastructure:** The Network Camera connects to the WLAN via an Access Point. (The default setting)
  - (1) TX rate:** This field is for selecting the maximum transmission rate on the network. The default setting is "auto". It means the Network Camera will try

to connect to the wireless device with the highest transmitting rate.

**(2) Security:** Select the data encryption method

- **None:** Do not use data encryption.
- **WEP:** Allows communication only with other devices which are with identical WEP settings.
- **WPA-PSK:** Use WPA pre-shared key.
- **WPA2-PSK:** Use WPA2 pre-shared key.

**(3) Auth Mode:** Choosing one of the following modes, (Default setting is OPEN).

- **Open:** communicates the key across the network.
- **Shared:** allows communication only with other devices with identical WEP settings.

**(4) Key length:** The administrator can select the key length of 64 or 128 bits. 64 bits is the default setting.

**(5) Key format:** Choose one of the following formats. **HEX** is the default setting.

- **HEX** digits consist of the numbers 0~9 and the letters A-F.
- **ASCII** is a code for representing English letters as numbers from 0-127 except “, <, > and space characters that are reserved.

**(6) Network Key:** Enter a key in either hexadecimal or ASCII format. When selecting different key length, acceptable input length is listed as following:  
64 bits key length: 10 Hex digits or 5 characters.

128 bites key length: 26 Hex digits or 13 characters.

Note: When 22(“), 3C(<) or 3E(>) are input in network key, the key format can't be changed to ASCII format.

**(7) Algorithm:** Choose one of the following algorithms for WPA-PSK modes:

- **TKIP**
- **AES**

**(8) Pre-shared Key”** Enter a key in ASCII format. The length of the key is 8 ~ 63

**2. Ad-Hoc:** Make the Network Camera connect directly to a host equipped with a wireless adapter in a peer-to-peer environment.

**(1) Channel:** Under infrastructure mode, the channel will be selected automatically to match the channel setting for the selected Access Point. Under Ad-Hoc mode, the channel must be manually set to the same channel for each wireless adapter. The default channel setting depends on the installed region.

**(2) TX rate:** This field is for selecting the maximum transmission rate on the network. The default setting is “auto”. It means the Network Camera will try to connect to the other wireless device with highest transmitting rate.

**(3) Security:** Select the data encrypt method

- **None:** Do not use data encryption.
- **WEP:** allows communication only with other devices with identical WEP settings.

**(4) Auth Mode:** Choose one of the following modes (Open is the default

setting).

- **Open** communicates the key across the network.
- **Shared** allows communication only with other devices, which are with identical WEP settings.

**(5) Key length:** The administrator can select the key length of 64 or 128 bits. 64 bits is the default setting.

**(6) Key format:** Choose one of the following formats. **HEX** is the default setting.

- **HEX** digits consist of the numbers 0~9 and the letters A-F.
- **ASCII** is a code for representing English letters as numbers from 0-127 except “, <, > and space characters that are reserved.

**(7) Default key/Network Key:** Enter a key in either hexadecimal or ASCII format. When selecting different key length, acceptable input length is listed as following:

64 bits key length: 10 Hex digits or 5 characters.

128 bites key length: 26 Hex digits or 13 characters.

Note: When 22(“), 3C(<) or 3E(>) are input in network key, the key format can't be changed to ASCII format.

## DDNS Setting

**1. Enable DDNS:** This option turns on the DDNS function.

**2. Host Name:** If the User wants to use DDNS service, this field must be filled. Please input the hostname that is registered in the DDNS server.

**3. E-mail:** The E-mail field is necessary for logging in the DDNS server or notify the User of the new IP address.

**4. Register:** Click on this button after filling in Host Name and E-mail to register for DDNS service.

**5. Finish:** Click on this button to save modified settings for the DDNS service.



## Access list

The screenshot shows the LevelOne web interface. At the top, the LevelOne logo is on the left and 'Access list 1.1.2.14' is on the right. A vertical navigation menu on the left contains the following items: Home, System, User management, Network, Access list (highlighted), Audio and video, Video record, Stream, Camera control, Application, Storage, System log, Status and parameters, and Maintenance. The main content area displays the 'Access list setting' dialog box. The dialog title is 'Access list setting' and the instruction is 'Please select add/delete the access list'. There are two radio buttons: 'Add denied address' (which is selected) and 'Delete denied address'. Under 'Add denied address', there are two input fields: 'Start IP address' and 'End IP address'. Under 'Delete denied address', there is a dropdown menu labeled 'Address list'. At the bottom right of the dialog are four buttons: 'Cancel', 'Prev', 'Next', and 'Finish'.

### Access list setting

1. **Add denied address:** This rule allows the user to assign a range of IP addresses to the Deny List.
2. **Delete denied address:** Delete IP address list from the Address List.

## Audio and Video setting

The screenshot shows the 'Audio and video' configuration page for a LevelOne camera. The interface includes a navigation sidebar on the left and a main content area with four distinct settings sections. Each section lists current values and provides a 'Setup' button for modification.

- General setting:** Current color mode is color; Current video flip is off / mirror is off; Current environment is Indoor; Current video frequency is 60hz.
- Video setting:** Current video contrast is 1; Current video brightness is 0; Current video saturation is 0; Current video sharpness is 0; Current video EV is 0; Current video gain is 1x ~ 8x.
- Infrared led setting:** The infrared led mode is auto mode, value is 3; The low lux mode is off.
- Audio setting:** The microphone is Internal microphone, and microphone volume is 40.

### General Setting

- 1. Color mode:** Select use color or monochrome video display.
- 2. Video orientation:** The orientation of video
  - (1) Flip:** Vertically rotate the video.

(2) **Mirror:** Horizontally rotates the video.

**3. Environment:** The orientation of video

(1) **Indoor:** This option is usually selected when the Network Camera is placed in indoor environments.

(2) **Outdoor:** This option is usually selected when the Network Camera is placed in outdoor environments.

**4. Power frequency:** Select 50 Hz or 60Hz power line frequency.

※The fluorescent light will flash according to the power line frequency that depends on local utility. Change the frequency setting to eliminate uncomfortable flash image when the light source is only fluorescent light.

### Video Setting

**1. Contrast:** Adjust the image contrast level, which ranges from -5 to +5. The default value is set to 0.

**2. Brightness:** Adjust the image brightness level, which ranges from -5 to +5. The default value is set to 0.

**3. Saturation:** Adjust the image saturation level, which ranges from -5 to +5. The default value is set to 0.

**4. Sharpness:** Adjust the image sharpness level, which ranges from -5 to +5. The default value is set to 0.

**5. EV:** Exposure value represent the expected target value of the luminance of the weighting result of AE windows in the image and its tolerance as offset.

**6. Gain:** In the slide bar of Gain, there are also two sliders, which represent the limitations to control the maximum gain value and the minimum one, respectively. Normally, the minimum value is to 1x for better quality.

### Infrared Led Setting

**1. "Infrared LED Control"** IR led for Day and Night (Option). User can turn on/off the built-in IR led. This function is very useful under low illumination environment.

(1) **Auto:** Select IR sensitivity from 0 to 4.

(2) **Manual:** Turn on/off the IR led manually.

- **Turn on:** Turn on led

- **Turn off:** Turn off led

**2. Low lux mode:** The video quality will be improved when the camera is in low lux environment.

(1) **Disable dark mode:** Disable low lux mode.

(2) **Enable dark mode:** Enable low lux mode.

### Audio Setting

**1. Mute:** Audio mute.

**2. Microphone Select:** Internal microphone or external microphone select.

**3. Mic Volume:** Adjust microphone volume, which ranges from 1 to 46. The default value is set to 40.

## Video record

### Schedule mode

- (1) **Every day:** Enable/Disable every day application.
- (2) **Week day:** Enable/Disable week day application.
- (3) **Selected day:** Enable/Disable selected day application.

### Schedule information

- (1) Enter the **Start time** and **Stop time** for day mode.  
Note that the time format is [hh:mm] and is expressed in 24-hour clock time.  
By default, the start and end time of day mode are set to 01:00:00 and 23:59:59.
- (2) **Sun/Mon/Tue/Wed/Thu/Fri/Sat:** Select the days of the week to perform the application.
- (3) **Start day** and **Start time** as the start timing the time. **End day** and **End time** as the end day the time.
- (4) **Enable cyclic recording:** The cyclic recording function is enabled, during

the transaction stage when a storage space is full and the incoming streaming data is about to overwrite the previously saved videos.

**Record parameters**

(1) **Source:** Select a stream for the recording source.

(2) **Recording interval:** Select the recording time interval.

(3) **Prefix file name:** You can setting the file name, and enable or disable to add the date and time on file name.

**Response mode:** There are three choices of server types available: NAS, SD Card, and USB storage. Select the item to display the detailed configuration options.

**(1)NAS**

- **NAS server address:** Enter IP address of the NAS server.
- **NAS shared directory:** Enter the NAS shared directory path.
- **Workgroup:** Enter the NAS workgroup parameter.
- **User account:** Enter the login name of the NAS account.
- **User password:** Enter the password of the NAS account.

**Note:** Video record with the Application must be set to the same shared directory path. If you would like do detail recording settings or multi-channel recording, please install the bundled 64-channel Video Management Software in the CD.

# Stream

## Audio codec setting

(1) **Audio codec type:** There are two choices of audio codec types available: **AMR** and **AAC**.

(2) **Bit rate**

-- **AMR** The bit rates are selectable at the following rates: 4750,5150,5900,6700,7400,7950,10200 and 12200.

-- **AAC** The bit rates are selectable at the following rates: 8Kbps, 16Kbps, 24Kbps and 32Kbps.

## Video codec setting

(1) **Select Stream:** The Network Camera supports **Stream 1** and **Stream 2**.

(2) **Video codec:** User can choose different video compression modes based

on requirement or application.

**(3) Video size:** Click the drop down bar to choose the quality of image

**(4) Connection type:** User can select this button to choose the better video & links quality. (Internet mode or Intranet mode)

**(5) Frame rate:** This limits the maximal refresh frame rate per second. Set the frame rate higher for a smoother video quality.

**(6) Intra frame period:** Determine how often to plant an "I frame". The shorter the duration, the more likely you will get a better video quality, but at the cost of higher network bandwidth consumption.

**(7) Video Quality type:** Setting optimizes bandwidth utilization and video quality.

-- **Constant bit rate:** User can adjust the video quality manually.

-- **Fixed quality:** User can select from lowest quality to get best quality according.

### **Snapshot and time display setting**

Adjust the photo size specifications and choose whether to mark time on the video and photo.

# Camera control

**Camera control**

Camera control 1.1.2.14

- Home
- System
- User management
- Network
- Access list
- Audio and video
- Video record
- Stream
- Camera control**
- Application
- Storage
- System log
- Status and parameters
- Maintenance

**Camera control**

2012-11-01 14:20:20

UL Up UR

Left Home Right

LL Down LR

Pan angle 30 Tilt angle 30

Auto pan speed 3

Patrol cycle 5 Patrol speed 3

**Preset point setting**

The current home position is default

The current auto pan range is default

The preset points list as following:  
a (210,15)

Setup

**Patrol list setting**

The patrol list is as following:  
none

Setup

## Camera control

The pan and tilt functions can be controlled with these buttons. The **Left** button controls the camera to the left; the **Right**, **Up**, and **Down** buttons control the camera accordingly.



- (1) **UL, UR, LL and LR** buttons control the camera to an oblique angle. And **Home** button controls the camera to the center.
- (2) **Pan angle:** This sets the range of the horizontal movement of the camera. The larger value is setting, the larger movement of **Left** or **Right** is performed by the camera.
- (3) **Tilt angle:** This sets the range of the vertical movement of the camera. The larger value is setting, the larger movement of **Up** or **Down** is performed by the camera.
- (4) **Patrol cycle:** It is the cycle of patrol function.
- (5) **Auto pan speed:** This defines the speed of auto panning. The larger value is setting, the faster the camera will move.
- (6) **Auto patrol speed:** This defines the speed of auto patrol. The larger value is setting, the faster the camera will move.

### Preset point setting

- (1) **Set the home position**
  - Set default value as home position:** Restore home position to original default home by clicking on this button.
  - Set the current position as home position:** Click on the button will set the current aimed position as home of the Network Camera. Each time the Network Camera reboots or finishes calibration, it will automatically aim to the defined home position
- (2) **Set the auto pan range**
  - Set default value as auto pan range:** Restore auto pan range to original default auto pan range by clicking on this button.
  - Set the auto pan range manually:** Click on the button will set the auto pan range of the Network Camera.
- (3) **Add or delete a preset point**
  - Add current point as a preset point:** If the User wants to save the current view as a preset location, enter a name to each of the current video view on **Preset points** and click on the **Finish** button. The camera allows for 20 preset locations.
  - Delete a preset point from below:** This keeps a list for preset positions. Clicking on the **Finish** button will remove the current selected position from the preset list.

### Patrol list setting

- (1) **Preset points:** The preset points box list all preset points. User must use to drag the preset points to **Patrol list** box. When the action is recognized, the **Patrol list** box changes to red.
- (2) **Patrol list:** The Patrol list box list all patrol points. Users use the drag to adjust of the patrol point (Up or down). **Dwelling time (sec):** The stop time of each preset location during auto patrols of the Network Camera.
- (3) **Remove patrol point:** The remove patrol point box will remove the patrol point.

# Application

The screenshot shows the LevelOne web interface. At the top, the LevelOne logo is on the left and 'Application 1.1.2.14' is on the right. A navigation menu on the left lists: Home, System, User management, Network, Access list, Audio and video, Video record, Stream, Camera control, Application (highlighted), Storage, System log, Status and parameters, and Maintenance. The main content area is titled 'Application setting' and contains the following information:

- Surveillance application is currently enabled
- The application sechedule is everyday  
time: from 00:00:00 to 23:59:59
- The application trigger type is digital input, high level trigger, and detecting next event after 5 second(s)
- The application media is system log
- digital output is restoring to original state after 3 second(s)
- The application trigger response is saving to SD card

A 'Setup' button is located at the bottom right of the settings area.

## Schedule mode

- (1) **Every day:** Enable/Disable every day application.
- (2) **Week day:** Enable/Disable week day application.
- (3) **Selected day:** Enable/Disable selected day application.

## Schedule information

- (1) Enter the **Start time** and **Stop time** for day mode.  
Note that the time format is [hh:mm:ss] and is expressed in 24-hour clock time. By default, the start and end time of day mode are set to 01:00:00 and 23:59:59.
- (2) **Sun/Mon/Tue/Wed/Thu/Fri/Sat:** Select the days of the week to perform the application.
- (3) **Start day** and **Start time** as the start timing the time. **End day** and **End time** as the end day the time.

## Trigger mode

- (1) **Video motion detection:** Enable/Disable video motion application.
- (2) **Periodically:** This option allows the Network Camera to trigger periodically for every other defined minute.
- (3) **Digital input:** This option allows the Network Camera to use an external digital input device or sensor as a trigger source. Depending on your application, there are many choices of digital input devices on the market which helps to detect changes in temperature, vibration, sound, and light, etc.

## Parameters

- (1) **Motion parameters:** Higher sensitivity and small threshold will allow easier motion detection.
- (2) **Period parameters:** This option allows the Network Camera to trigger periodically for every other defined seconds. Up to 999 seconds are allowed.
- (3) **Digital input parameters:** Select the digital input type and set trigger time.

## Media mode

There are three choices of media types available: **Snapshot**, **Generate digital output signal**, **Record (Motion Detection only)** and **System log**.

## Snapshot & Record file setting

You can setting the file name, and enable or disable to add the date and time on file name. Can setting the digital output duration seconds.

## Response mode

There are five choices of server types available: Email, FTP, NAS, SD Card, and USB storage. Select the item to display the detailed configuration options.

### (1) Email

- **Email security mode:** If your SMTP server requires a secure connection (SSL or TLS), check this server requires a secure connection (SSL or TLS).
- **Sender email address:** Enter the email address of the sender.
- **Recipient email address:** Enter the email address of the recipient.
- **Server address:** Enter the domain name or IP address of the email server.
- **User name:** Enter the user name of the email account if necessary.
- **Password:** Enter the password of the email account if necessary
- **Server port:** The default mail server port is set to 25. You can also manually set another port.

### (2) FTP

- **Server address:** Enter the domain name or IP address of the FTP server.
- **Server port:** By default, the FTP server port is set to 21.
- **User name:** Enter the login name of the FTP account.

- **Password:** Enter the password of the FTP account.
- **FTP folder name:** Enter the folder where the media file will be placed. If the folder name does not exist, the Network Camera will create one on the FTP server.

**(3) NAS**

- **NAS server address:** Enter IP address of the NAS server.
- **NAS shared directory:** Enter the NAS shared directory path.
- **Workgroup:** Enter the NAS workgroup parameter.
- **User account:** Enter the login name of the NAS account
- **User password:** Enter the password of the NAS account.

**Note:** Video record with the Application must be set to the same shared directory path. If you would like do detail recording settings or multi-channel recording, please install the bundled 64-channel Video Management Software in the CD.

## Storage

Manage the storage device (like SD card or USB flash disk).

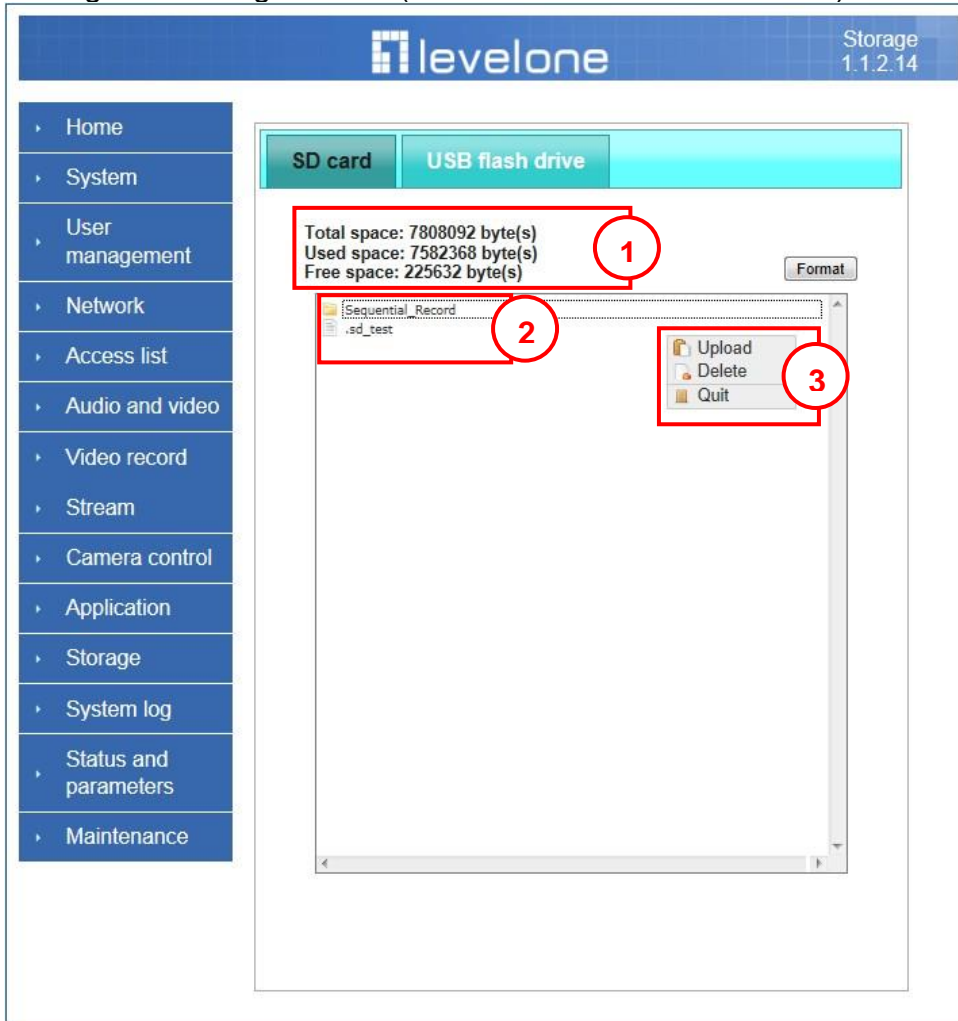

### Storage Status

Displays the storage device information.

### File operation

Move the mouse over the file. Press the mouse right button that Right-click menu is displayed. You can delete files.

Move the mouse over the directory. Press the mouse left button that the file structure expand. Press the mouse right button that Right-click menu is displayed. You can choose upload or delete files.

**NOTE :** Allow the user to upload or delete files when the storage device is not write-protected. If the SD card can't be detected, please link to the following URL: <http://www.sdcard.org/consumers/formatter> to download the "SD Formatter Kit" formatting your SD card.

## Syslog

The screenshot displays the LevelOne web interface for system log management. The top navigation bar includes the LevelOne logo and the text 'System log 1.1.2.14'. A left-hand menu lists various system functions: Home, System, User management, Network, Access list, Audio and video, Video record, Stream, Camera control, Application, Storage, System log, Status and parameters, and Maintenance. The main content area is divided into two sections:

- Remote log setting:** This section shows the 'Remote log server' status as 'Disable'. A 'Setup' button is located to the right of this status.
- Current log:** This section displays a scrollable list of system log messages. The messages include timestamps, device identifiers (FCS-6020), and descriptions of system events such as process restarts, network interface status, and service errors.

The Network camera supports log the system messages on remote server. The protocol is compliant to RFC 3164. If you have external Linux server with sys log service, use “-r” option to turn on the facility for receiving log from remote machine. Or you can use some software on Windows that is compliant to RFC 3164. An example is Kiwi Syslog Daemon. Visit <http://www.kiwisyslog.com/kiwi-syslog-daemon-overview/>.

Check **Setup** and **Enable** then input the **IP address** and **port** number of the log server to enable the remote log facility.

In the **Current log**, it displays the current system log file. The content of the log provides useful information about configuration and connection after system boot-up. Click on **Finish** to save modify settings.

## Status and Parameters

User can find a lot of information about the system such as **Upnp port forwarding**, **Traversing NAT**, **Public IP** and so on. User also can get the number of current viewer of the Network Camera here.

**Status**

Upnp port forwarding  
Success

Traversing NAT  
Failure

Public ip  
118.166.201.143:8403

Current viewers  
0

**Parameters**

```
<html><head>
<meta http-equiv="content-type" content="text/html; charset=UTF-
<link rel="stylesheet" type="text/css" href="../../style/syslog.css
</head><body>
<p id="view-parameters">
[System parameters]<br>
hostName="WCS-6020";<br>
enableLed=true;<br>
timeZone=80;<br>
supportAutoDST=false;<br>
enableDST=false;<br>
timeMethod=0;<br>
ntpServer="time.stdtime.gov.tw";<br>
updateInterval=1;<br>
doActState=false;<br>
diActState="high";<br>
doCurState=true;<br>
diCurState="high";<br>
doState="false";<br>
connection="false";<br>
doState=false;<br>
connection=false;<br>
nu_Fw=6;<br>
<br>
[Network parameters]<br>
networkTune="lan";<br>
```



## Maintenance

1. **Reboot system:** The **Reboot** button will reboot the Network Camera. It's useful while the Network Camera has problems and needs to be rebooted.
2. **Restore system:** Click on **Restore** button on the configuration page to restore the factory default settings. Restore all settings to factory default except settings in **Network type** and **Root Password**. The system will restart and require the installer program to set up the network again.
3. **Calibrate:** Recalibrate the home position to the default center to recover the tolerance caused by some external forces. Please note that there is no confirming message box after clicking on the **Calibrate** button. The Network Camera will calibrate immediately.
4. **Upgrade firmware:** Select the firmware file and click upgrade button. Please be aware that you should not turn off the power during updating the firmware and wait for finish message.



***Warning: The upgrade firmware procedure cannot be interrupted. If the power and/or network connection are broken during the procedure, it might possibly cause serious damage to the Network Camera.***

Note: When upgrading firmware please wait for 90~180 seconds, and then you can connect to Network Camera again. The system will restart and require the installer program to set up the network again.

## Appendix

### A. Troubleshooting & Frequently Asked Questions

#### Q1: Status led does not light up.

A1: First, make sure that 「 Configuration>System>Turn off the LED indicator 」 is disabled. If it is, check the item, and the led should light up. Second, if red led does not light up, please check that the power adapter in the package is plugged correctly. And last, if green led does not light up; please check that category 5 UTP cable is plugged correctly.

If the problem is still not solved, please contact your dealer for further help.

#### Q2: What kind of Ethernet cable is used by network camera?

A2: The network Camera uses Category 5 UTP cable allowing 10 and/or 100 Base-T networking.

#### Q3: The Network Camera will be installed and work if a firewall exists on the network?

A3: There are two way to set up the IP camera at Internet.

(1) By UPnP Port Forwarding

1. Select an IP router. It must support UPnP port forwarding and enable this function first.

##### UPnP Settings

You can setup this item if you want to enable UPnP.

Enabled  Disabled

2. Connect camera RJ45 cable to IP router and the router is also connected to Internet.
3. Plug power cord to camera.
4. Go to camera Network page. Enable UPnP port forwarding

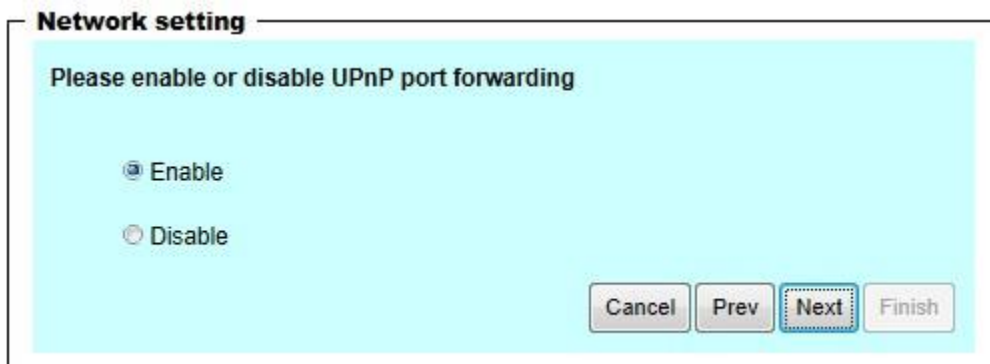

5. Check camera status, we can see the ports had been successfully opened.

**Status**

**Upnp port forwarding**  
Failure

**Traversing NAT**  
Failure

**Public ip**  
192.168.228.217.8080

**Current viewers**  
0

6. Type IP address:8080 at browser. Then you can see camera through Internet.

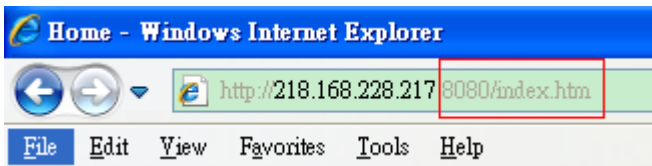

7. You can also type the DDNS name at below label of camera on browser URL field. For example, you may type *user01.C2.mylevel1.com:8080*.

(2) By Setting Port Forwarding Manually

1. Select a router. Set the port forwarding as following.

Virtual Server Lists 17 / 32 (Number / Total)

Name	Private IP	Protocol	Schedule	
<input type="checkbox"/> Virtual Server FTP	0.0.0.0	TCP 21/21	Always	
<input type="checkbox"/> Virtual Server HTTP	0.0.0.0	TCP 80/80	Always	
<input checked="" type="checkbox"/> PTCam	192.168.0.100	TCP 443/443	Always	
<input type="checkbox"/> Virtual Server DNS	0.0.0.0	UDP 53/53	Always	
<input type="checkbox"/> Virtual Server SMTP	0.0.0.0	TCP 25/25	Always	
<input type="checkbox"/> Virtual Server POP3	0.0.0.0	TCP 110/110	Always	
<input type="checkbox"/> Virtual Server Telnet	0.0.0.0	TCP 23/23	Always	
<input type="checkbox"/> IPsec	0.0.0.0	UDP 500/500	Always	
<input type="checkbox"/> PPTP	0.0.0.0	TCP 1723/1723	Always	
<input type="checkbox"/> NetMeeting	0.0.0.0	TCP 1720/1720	Always	
<input type="checkbox"/> DCS-1000	0.0.0.0	TCP 80/80	Always	
<input type="checkbox"/> DCS-2000	0.0.0.0	TCP 80/80	Always	
<input type="checkbox"/> DVC-1000	0.0.0.0	TCP 1720/1720	Always	
<input checked="" type="checkbox"/> PTCarr	192.168.0.100	TCP 80/80	Always	
<input checked="" type="checkbox"/> PTCam	192.168.0.100	UDP 53/53	Always	
<input checked="" type="checkbox"/> PTCam	192.168.0.100	TCP 554/554	Always	
<input checked="" type="checkbox"/> 28067	192.168.0.102	TCP 28067/28067	Always	

PS. Port 80 is HTTP Port, port 53 is stream port, port 554 is RTSP port. and port 443 is HTTPS port.

2. Go to camera Network page. Disable UPnP port forwarding function.

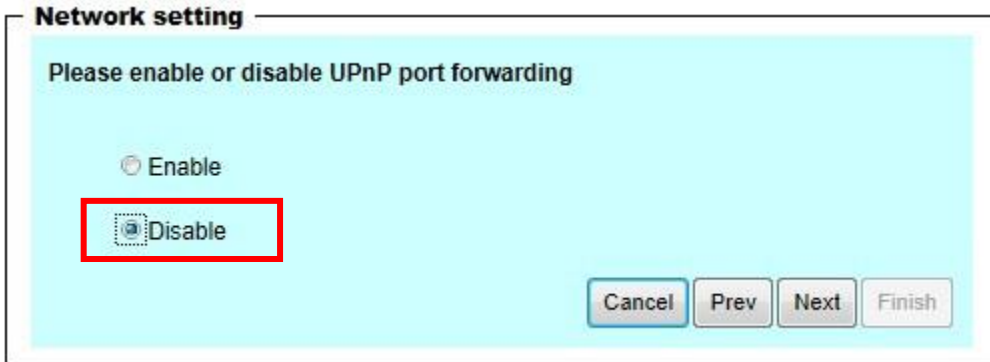

The screenshot shows a 'Network setting' window with the title 'Please enable or disable UPnP port forwarding'. There are two radio buttons: 'Enable' and 'Disable'. The 'Disable' button is selected and highlighted with a red rectangle. At the bottom right, there are four buttons: 'Cancel', 'Prev', 'Next', and 'Finish'.

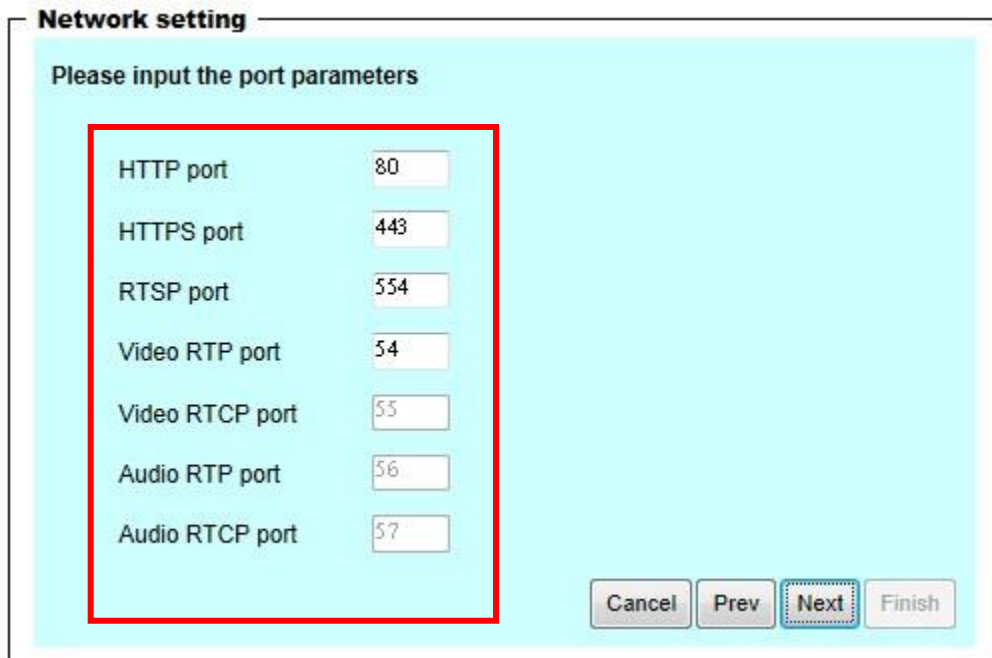

The screenshot shows a 'Network setting' window with the title 'Please input the port parameters'. It contains a table of port settings, all of which are highlighted with a red rectangle:

HTTP port	80
HTTPS port	443
RTSP port	554
Video RTP port	54
Video RTCP port	55
Audio RTP port	56
Audio RTCP port	57

At the bottom right, there are four buttons: 'Cancel', 'Prev', 'Next', and 'Finish'. The 'Next' button is highlighted with a blue dotted border.

3. Type IP address at browser. Then you can see camera through Internet.

4. You can also type the DDNS name at below label of camera on browser URL field. For example, you may type *user01.C2.mylevel1.com*.

**Note: The firewall software at PC may block the transfer of network camera. Please remove or stop the kind software.**

**Q4: What is the default name and password of administrator?**

A4: The name is **root** and the password is *<blank>*.

**Q5: How can I find the network camera in the local area network?**

A5: By using the CamFinder program in the CD or using UPnP to find it.

**Q6: CamFinder cannot find Network Camera in the local area network at first time?**

A6: Make sure the subnet of network camera is same as your PC. If the local area network supports DHCP, the camera is "Get IP address automatically" in the "Network" page default. If the local area network does not support DHCP, change your PC IP address to "192.168.0.xxx".

**Q7: How can I restore the network camera to default value?**

A7: Use a gem clip to press on the inside button until the led flashing. After three cycles of the flashing, the network camera begins to restore default value.



**Q8: Infrared led does not light up?**

A8: Check 「 Configuration>Audio and Video>Infrared LED Control 」 is **Auto** or **Manual**. Turn on.

**Q9: The network camera cannot focus accurately.**

A9:

- (1) The lens is dirty or dust is attached. Clean the lens with lens cleaner. And then adjust the camera focus manually.
- (2) The image may be out of focus. If the object is too near, move the object away from Network Camera.

**Q10: The cover of network camera is warm. Is it normal?**

A10: Network camera is a precision device. The internal material has the operational temperature, and it is normal when user touch the cover feels warm. It is recommended to put the network camera at aired place and away from any other device.

**Q11: What is the scope of wireless network camera connecting AP?**

A11: The scope of wireless connection is different from the environment. The possible interference is (1) the direction of antenna (2) the material and architecture of building (3) the temperature of environment (4) the position of the network camera.

**Q12: The process of upgrade firmware aborted.**

A12: Contact your dealer for further help.

**Q13: Cannot access the login page and other web pages of Network Camera from Internet Explorer**

A13:

- May be due to the network cable. Try correcting your network cable and configuration. Test the network interface by connecting a local computer to the Network Camera via a crossover cable.
- Make sure the Internet connection and setting is ok.
- Make sure enter the IP address of Internet Explorer is correct. If Network Camera has a dynamic address, it may have changed since you last checked it.
- Network congestion may prevent the web page appearing quickly. Wait for a while.

The IP address and Subnet Mask of the PC and Network Camera must be in the same class of the private IP address on the LAN.

- Make sure the http port used by the Network Camera, default=80, is forward to the Network Camera's private IP address.
- The port number assigned in your Network Camera might not be available via Internet. Check your ISP for available port.
- The proxy server may prevent you from connecting directly to Network Camera, set up not to use the proxy server.
- Confirm that Default Gateway address is correct.
- The router needs Port Forwarding feature. Refer to your router's manual for details.
- Packet Filtering of the router may prohibit access from an external network. Refer to your router's manual for details.
- Access Network Camera from the Internet with the global IP address of the router and port number of Network Camera.
- Some routers reject the global IP address to access Network Camera on the same LAN. Access with the private IP address and correct port number of Network Camera.
- When you use DDNS, you need to set Default Gateway and DNS server address.
- If it's not working after above procedure, reset Network Camera to default setting and installed it again.
- Maybe the IP Address of the Network Camera is already being used by another device or computer.
- If the problem is not solved, the Network Camera might be faulty. Contact your dealer for further help.

## B. Technical specifications

FCS-6020	
<b>Camera</b>	
Image Sensor	2-Megapixel 1/2.7" Progressive CMOS
Effective Pixels	1920x1080
Lens	Board lens, fixed-focal, f=4.0 mm, F2.0
Angle of View (H)	62 °
Minimum Illumination	Color: 1.5 lux at F2.0 B/W: 1.0 lux at F2.0
IR Cut Filter	Removable infrared-cut filter for day & night function
Shutter Time	1 to 1/10000 sec.
Pan/Tilt/Zoom	Pan range: ±355 ° (-177.5° ~ 177.5°) Tilt range: ±135 ° (-45° ~ 90°) Auto pan mode Auto patrol mode
IR LED	12 IR LEDs for illumination up to 10m
<b>Video</b>	
Video Compression	H.264 / MPEG4 / MJPEG
Resolutions	1080p(1920x1080) / SXGA(1280x1024) / WXGA(1280x800) / VGA(640x480) / QVGA(320x240) / QCIF(176x144)
Frame Rate	Up to 30 fps at 1920x1080
Video Streaming	Multiple simultaneous streams, up to 2 streams
Image Setting	- Adjustable image size, quality and bit rate - Configurable brightness, sharpness, contrast, saturation, white balance and exposure - AGC/AWB/AES - Flip & Mirror - Time Stamp
Video Format	AVI
<b>Audio</b>	
Audio Streaming	2-way audio
Audio Compression	G.726 / AMR
Audio Input/Output	Built-in microphone Mic/line input, line output
<b>Network</b>	
Networking	10/100 Mbps Ethernet, RJ-45 Built-in 802.11b/g/n WLAN
Security	Multi-level user access with password protection IP address filtering
Supported protocols	TCP/IP, HTTP, SMTP, FTP, DDNS, UPnP, Telnet, NTP, PPPoE, DNS, DHCP, RTSP, Samba
Number of clients	20
DNS	Easy Internet monitoring via configuration free Level1DNS™ service

Alarm and Event Management	
Motion Detection	16 Detection Zones
Notification	FTP, SMTP, Samba
DI/DO	1 D/I and 1 D/O for external sensor and alarm
General	
Local storage	SD/SDHC card slot, USB slot
Power	DC12V 1.5A
Power Consumption (Max.)	12W
Connectors	RJ-45 10BASE-T/100BASE-TX 3.5mm line out 3.5mm mic/line in I/O terminal block (DI/DO) DC Power Jack
LED Indicator	Power/Link
Button	Reset Button
Operating Temperature (°C)	0°C ~ 40°C
Operating Humidity (Non-condensing)	10% to 80%
Dimensions	105 x 105 x 110 mm
Weight	356 g
Approvals	CE, FCC
Viewing System Requirements	OS: Microsoft Windows 7/Vista/XP Browser: Internet Explorer 6.x or above, Firefox, Chrome, Safari Cell phone: 3GPP player Real Player: 10.5 or above Quick Time 6.5 or above
Bundled Software	Bundled with 64-Channel LevelOne OneSecure surveillance management software

## Notification of Compliance

Appendix C

### Europe - EU Declaration of Conformity



For complete DoC please visit

<http://global.level1.com/downloads.php?action=init>

### GPL License Agreement

GPL may be included in this product, to view the GPL license agreement goes to

<http://download.level1.com/level1/gpl/GPL.pdf>

For GNU General Public License (GPL) related information, please visit

<http://global.level1.com/downloads.php?action=init>