



LevelOne

**FUS-3100 / FPS-3003 / WUS-3200
MFP Server**

User Manual

Safety

FCC WARNING

This equipment may generate or use radio frequency energy. Changes or modifications to this equipment may cause harmful interference unless the modifications are expressly approved in the instruction manual. The user could lose the authority to operate this equipment if an unauthorized change or modification is made.

This equipment has been tested and found to comply with the limits for a Class B digital device, pursuant to Part 15 of the FCC Rules. These limits are designed to provide reasonable protection against harmful interference in a residential installation. This equipment generates, uses, and can radiate radio frequency energy and, if not installed and used in accordance with the instructions, may cause harmful interference to radio communications. However, there is no guarantee that interference will not occur in a particular installation. If this equipment does cause harmful interference to radio or television reception, which can be determined by turning the equipment off and on, the user is encouraged to try to correct the interference by one or more of the following measures:

- 1) Reorient or relocate the receiving antenna.
- 2) Increase the separation between the equipment and receiver.
- 3) Connect the equipment into an outlet on a circuit different from that to which the receiver is connected.
- 4) Consult the dealer or an experienced radio/TV technician for help.

CE Declaration of conformity

This equipment complies with the requirements relating to electromagnetic compatibility, EN 55022 class B for ITE, the essential protection requirement of Council Directive 89/336/EEC on the approximation of the laws of the Member States relating to electromagnetic compatibility.

CE Marking Warning

Hereby, Digital Data Communications, declares that this (Model-no. WUS-3200) is in compliance with the essential requirements and other relevant provisions of Directive 1999/5/EC.

The CE-Declaration of Conformity can be downloaded at:

<http://www.levelone.eu/support.php>



Table of Contents

INTRODUCTION	6
ABOUT THIS MANUAL.....	6
CUSTOMER SUPPORT.....	6
1. PRODUCT OVERVIEW.....	7
PACKAGE CONTENTS.....	7
PRODUCT CD.....	7
START-UP PROCEDURES.....	7
PHYSICAL DESCRIPTION	7
CONFIGURATION AND MANAGEMENT	8
FEATURES AND BENEFITS	8
2. BASIC INSTALLATION.....	9
CONNECTING THE HARDWARE.....	9
ASSIGNING AN IP ADDRESS TO THE SERVER.....	9
<i>Preliminary.....</i>	<i>9</i>
<i>IP Address.....</i>	<i>9</i>
<i>Host Names and Host Name Rules</i>	<i>10</i>
<i>Setting the IP Address Using DHCP</i>	<i>10</i>
<i>Setting the IP Address Using the Control Center</i>	<i>10</i>
<i>Setting the IP Address Using MFP Server's Web Pages</i>	<i>13</i>
WIRELESS CONFIGURATION.....	15
<i>Preliminary.....</i>	<i>15</i>
<i>Set Wireless Configuration Using MFP Server Control Center</i>	<i>15</i>
<i>Set Wireless Configuration Using MFP Server's Web Page</i>	<i>19</i>
3. USING THE MFP SERVER	23
INTRODUCTION TO THE NEW TECHNOLOGY OF MFP SERVER.....	23
CONNECT & DISCONNECT.....	23
HOW TO USE	24
<i>Driver Installation</i>	<i>24</i>
<i>Set Auto-Connect Printer</i>	<i>26</i>
<i>Manual-Connect Scanner</i>	<i>29</i>

<i>Auto-Connect Scanner</i>	31
<i>Manual-Connect / Auto-Connect Fax</i>	32
MANUAL-CONNECT VS AUTO-CONNECT	34
LIMITATIONS.....	35
CONNECTING PERIOD FOR AUTO CONNECT AND MANUAL CONNECT	35
4. THE CONTROL CENTER UTILITY	36
INSTALLING CONTROL CENTER UTILITY	36
USING THE CONTROL CENTER UTILITY.....	36
<i>Using Tools of Control Center Utility</i>	36
<i>Displaying MFP Server Status</i>	37
<i>Setting up MFP Server Configuration</i>	37
QUITTING THE CONTROL CENTER UTILITY	42
5. FILE SERVER	43
PRELIMINARY.....	43
STORAGE NAMES.....	44
CONNECTING USB MASS STORAGE TO THE SERVER	44
SUPPORTED CODEPAGES	44
<i>What is codepage?</i>	44
<i>Filename Encoding of FAT File System</i>	44
<i>When do you need to configure codepage?</i>	45
<i>Configuring the Server's Codepages</i>	45
ADDING USB MASS STORAGES TO NETWORK WITH SECURITY	47
<i>Setting up File Server Using the Control Center Utility</i>	48
<i>Setting up File Server Using Web Pages</i>	50
<i>Using Shared Storages by SMB/CIFS Method for Windows</i>	51
<i>Using Shared Storage by FTP Methods for Windows</i>	53
6. MFP SERVER'S WEB PAGES.....	54
INTRODUCTION	54
USING THE SERVER'S WEB PAGES	54
<i>Displaying Server Status</i>	54
<i>Setting up Server Configuration</i>	55
7. UPGRADE FIRMWARE	57
PROCEDURE A: USING THE CONTROL CENTER UTILITY	57

8. RESTORE FACTORY DEFAULTS	59
USING THE CONTROL CENTER UTILITY.....	59
USING THE SERVER'S WEB PAGES	59
USING INIT BUTTON.....	60
DEFAULT PARAMETERS LIST.....	60
9. THE INIT BUTTON	62
10. TROUBLESHOOTING.....	63
LED INDICATORS	63
IF AUTO-CONNECT DOES NOT WORK.....	63
FIREWALL.....	63

Introduction

Thank you for purchasing LevelOne MFP Server (in the following referred to as “**MFP Server**”). The MFP Server is designed to connect with All-In-One device or Multifunction Peripheral such as printers, and scanners, to the network, allowing all network users to access the USB devices.

About this Manual

This manual provides introductory information as well as detailed instructions on how to set up and manage MFP Server in various network environments. LevelOne offers 3 models of MFP Server; all models have a 10/100Mbps LAN port. However, FUS-3100 has only one USB port, while both FPS-3003 and WUS-3200 have two USB ports. Compared with FPS-3003, WUS-3200 offers an additional wireless module (802.11b/g). Except for the wireless configuration, most configuration and operations are similar between all models. Unless explicitly specified, all instructions in this user manual apply to LevelOne MFP Servers.

To fully benefit from this document, user should be familiar with basic networking principles. The instructions described in this manual are based on the setup for new MFP Server. To reload the Factory Parameters, user can reset this MFP Server back to Factory Default, which will restore most of the settings. For details, please refer to the chapter “**Restore Factory Defaults**”.

Customer Support

Should you require any technical assistance, please contact with your local dealer. Or please visit our website at <http://www.level1.com> for latest product information.

This document is subject to changes without prior notice.

1. Product Overview

Package Contents

Verify that nothing is missing from the package by using the checking list below. Please contact your local dealer if anything is missing or damaged. All packing materials are recyclable. Please confirm the items in the package below:

- MFP Server (FUS-3100 / FPS-3003 / WUS-3200)
- Power Adapter
- CD Manual/Utility
- Quick Installation Guide

Product CD

The CD contains MFP Server Control Center software, User Manual and Quick Installation Guide.

Start-up Procedures

If user's computer is configured to auto start CDs, this CD will start automatically when inserted. User can also navigate to the CD and start the autorun.exe file from within the Windows file manager.

Physical Description

Power Adaptor Connector: DC IN 12V/1A adaptor

Init Button: to initialize MFP Server (factory default)

Ethernet Connector: RJ-45 connector

USB Host Ports: USB 1.1/2.0 compliant

Indicators

- *Power Indicator* is lit up while power is applied. If the LED did not light up, or if it blinks, there is a problem with the MFP Server or power adapter.

- *Link/LAN Status* is lit up while network is applied. If the LED did not light up, then this MFP server may not connect to the network properly.
- *Wireless Indicator (WUS-3200)* is lit while wireless network is applied. If it is not lit, it indicates that the MFP server does not connect to wireless network (in the last firmware implementation, wireless station mode access is disable while Ethernet network is applied).
- *ACT/Status (FUS-3100/FPS-3003) Indicator* blinks to indicate network activity.
- *USB Indicator* is lit up while USB device connects to USB Port of MFP Server. If it does not light up, or if it blinks, please check the USB device and MFP Server.

Configuration and Management

The MFP Server can be configured and managed from its internal web pages or from the *Control Center*. These web pages or PC tools offer user a management tool suitable for all supported network environments.

Features and Benefits

MFP Server provides the following features and benefits:

Reliability: The MFP Server provides high performance and reliability combined with low power consumption.

Easy to Install: The MFP Server installs, operates, and is managed in a reliable and easy fashion.

Security: Able to assign administrator name and password to restrict login.

Monitoring: MFP Server's web pages and user software allows user to continuously monitor the status of connected USB devices.

Future Proof: The firmware stored in the MFP Server's Flash memory can be upgraded over the network. This allows user to quickly update and enhance its operational features when new software becomes available.

2. Basic Installation

Connecting the Hardware

- Connect the MFP Server to the network with a twisted-pair cat.5 or cat.6 cable, 10baseT or 100baseTX.
- Connect the Power Adapter to the MFP Server. The power indicator will light up and USB indicators will flash. When the Link indicator lights up, the MFP Server has properly connected to the network.
- Please make sure the USB device is switched off before connect to the MFP Server.
- Connect the USB device to the USB port with the USB cable.
- Turn on the USB device and make sure it is ready for use.

Assigning an IP Address to the Server

Preliminary

- If there is DHCP server available on the network, the MFP Server will grant an IP address automatically. The IP address will then appear on the *Control Center*. If there is no DHCP server to assign IP address to the MFP Server, the MFP Server will use the Factory default IP address as 192.168.1.100.

IP Address

The Control Center will automatically search MFP Server and list its IP address.

Fix IP Address

Manually assign IP; user must obtain an unused IP address from your network administrator.

Host Names and Host Name Rules

The default Host Name of the MFP Server is “FUS-3100”, “FPS-3003” or “WUS-3200”, depend on the model user has purchased.

If user installs two or more MFP Servers with same model type in the local area network, to avoid conflict by using the same Host Name, user should change the Host Name by using the Control Center or access to the MFP Server’s web pages. The Host Name should be no longer than 15 characters.

Setting the IP Address Using DHCP

Follow the instructions below to get an IP address using DHCP:

1. Edit or create a scope in the DHCP manager of the DHCP daemon. The entries included in this scope should contain the following parameters:
 - range of IP addresses
 - subnet mask
 - default router IP address
 - DNS server IP address
 - lease duration
2. Activate the scope. MFP Server automatically gets the DHCP parameters. If user is using DNS, it should include at least one DNS server IP address in the DHCP scope or manually set the DNS server IP address using MFP Server’s web pages or the Control Center.

Setting the IP Address Using the Control Center

1. Install the Control Center. The Control Center is available in the Product CD. Follow the on-screen display to complete the Control Center installation.
2. Start the Control Center and Auto-searching MFP Server window will appear.



3. If the tool finds multiple MFP Servers in the local area network, user has to select one of the MFP Servers from the Server List.



4. Double click the highlight list and enter the MFP Server's administrator (default: *admin*) and password (default: *admin*).



5. After logged in successfully, select TCP/IP from the MFP Server menu. IP Address setting dialog appears.

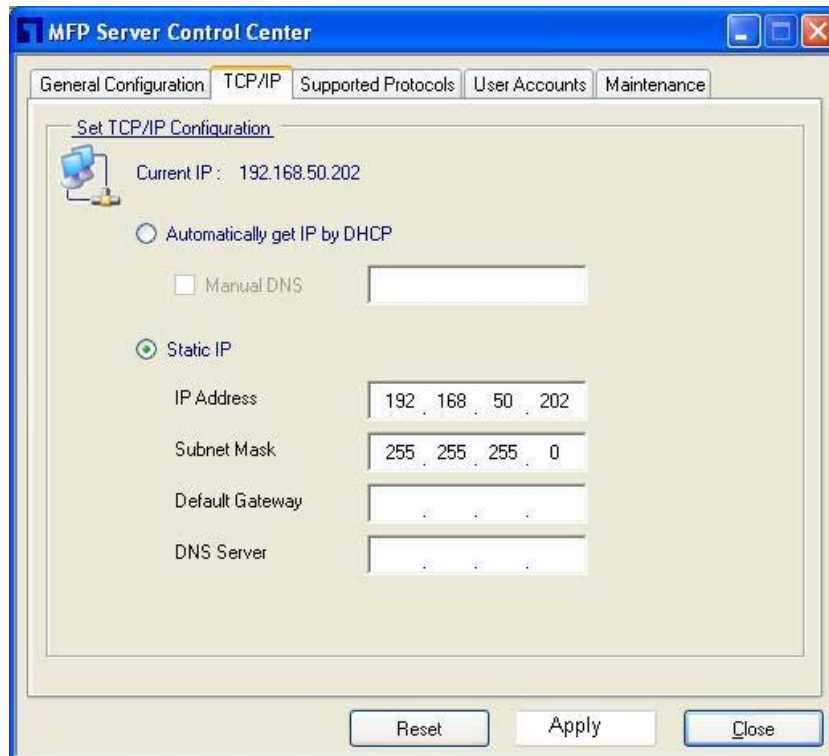

6. Select the prefer IP setting method corresponding to the local area network (static or dynamic using DHCP). When assigning a static IP address user also has to define Subnet Mask and Default Gateway. If user chooses **Automatically get IP by DHCP**, he/she can use desired DNS by clicking the **Manual DNS** button and manually assigning a DNS.
7. Click **Apply** to save the settings. And the MFP Server will reboot.
8. When reboot is completed, device has now finished the procedure of setting the IP address.

Setting the IP Address Using MFP Server's Web Pages

1. The IP address of MFP Server will display in the Server List. Open IE Browser and then enter the MFP Server's IP address or click the Home Icon  of the Control Center to access the MFP Server's Homepage.



2. Go to the web page and click on **CONFIG** icon.

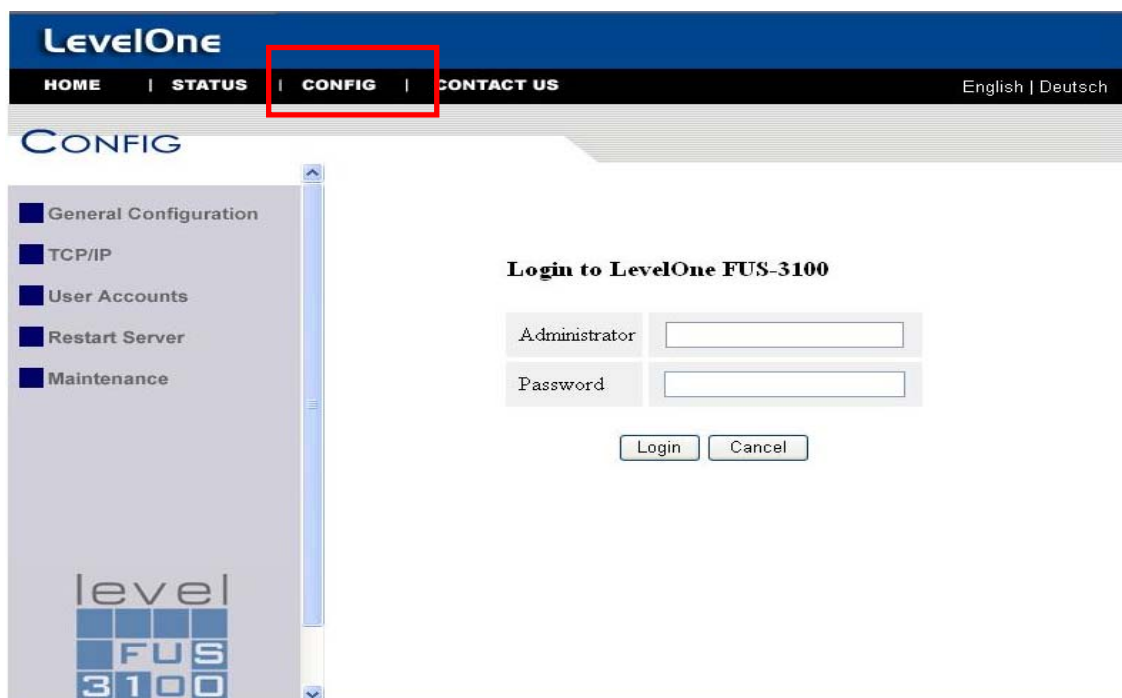

3. Enter administrator (default: *admin*) and password (default: *admin*).
4. Click **TCP/IP** icon.

The screenshot shows a web-based configuration interface titled "CONFIG". On the left is a vertical navigation menu with the following items: "General Configuration", "TCP/IP" (highlighted in blue), "User Accounts", "Restart Server", and "Maintenance". At the bottom of the menu is the "level" logo with "FUS 3100" below it. The main content area is titled "Set TCP/IP Configuration" and has a sub-header "TCP/IP". There are two radio button options: "Automatically get IP by DHCP" (which is selected) and "Static IP". Under the "Static IP" option, there are four input fields: "IP Address" (containing "192.168.1.100"), "Subnet Mask" (containing "255.255.255.0"), "Default Gateway", and "DNS Server". Below these fields are two buttons: "Submit" and "Reset".

5. Select the prefer IP setting method corresponding to the local area network (static or dynamic using DHCP). When assigning a static IP address user also has to define Subnet Mask and Default Gateway. If user chooses **Automatically get IP by DHCP**, he/she can use desired DNS by clicking the **Manual DNS** button and manually assigning a DNS.
6. Click **Submit** to save settings, the MFP Server will then reboot. Once reboot is completed, the device has now finished the procedure of setting the IP address.

Wireless configuration

Preliminary

- Before access the wireless network, wireless parameters should be set correctly. Users **have to** setup the first wireless parameter set through LAN connection.
- Wireless access can be set as 1. Infrastructure (station) mode, which need an access point to route network messages, or 2. Ad-hoc mode, which connect nearby wireless PC/devices with the same SSID (Service Set ID).
- Wireless access can be secured by WEP64, WEP128, or WPA-PSK/TKIP.
- In infrastructure mode, if network administrator wants to change any security related parameters, WUS-3200 **should be** changed first, and then access point. If parameters mismatch causes wireless access is not allowed, users **have to** modify those parameters through LAN connection.
- In infrastructure mode, the maximal transfer rate is 54 Mbps depending on access point's capability. In ad-hoc mode, only 802.11b (the maximal transfer rate is 11 Mbps) is allowed by specification.

Set Wireless Configuration Using MFP Server Control Center

- Install MFP Server Control Center utility. MFP Server Control Center utility is available in the Product CD.
- Start MFP Server Control Center utility and Auto-searching MFP server window will appear.



Note

If the wireless parameters are not correct or haven't been setup yet, user must to use LAN to access MFP Server Control Center.

- If the tool finds MFP servers in the local area network, then users have to select a MFP server from the server list.

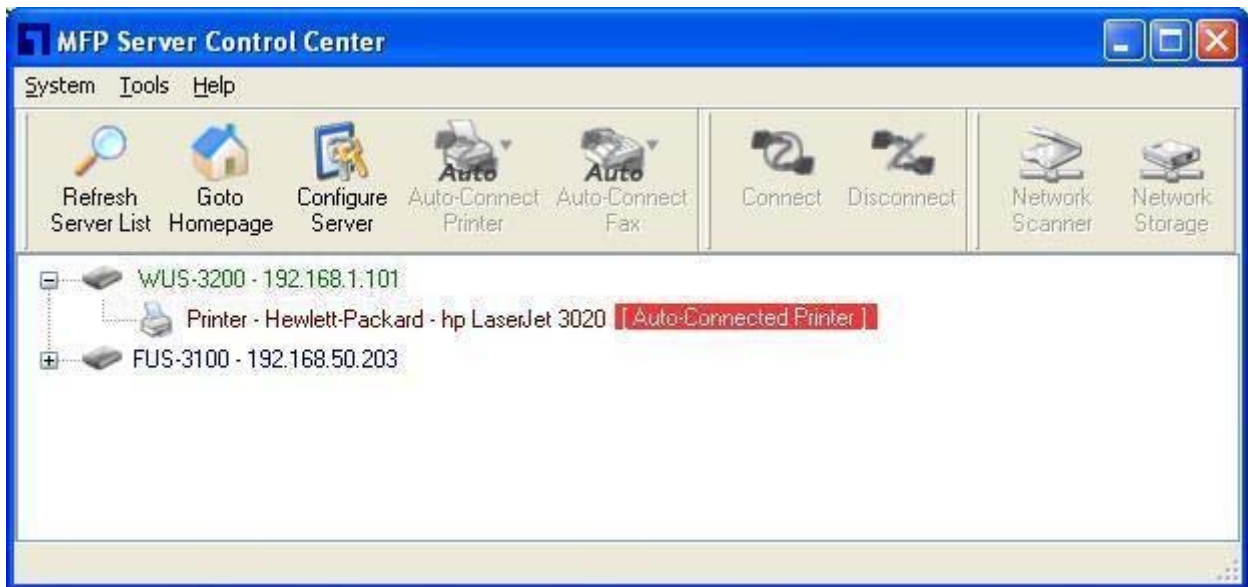

- Double click the highlight list and type the server's administrator (default: *admin*) and password (default: *admin*).

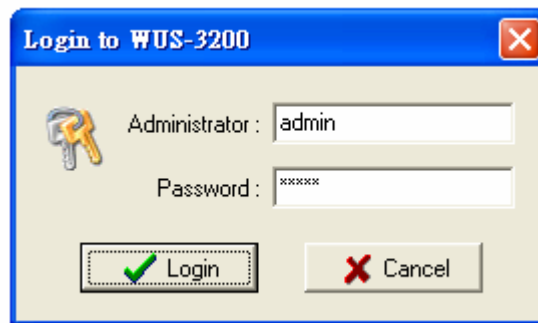

- When login successfully, from the MFP Server menu, select wireless. Then Wireless dialog setting appears.

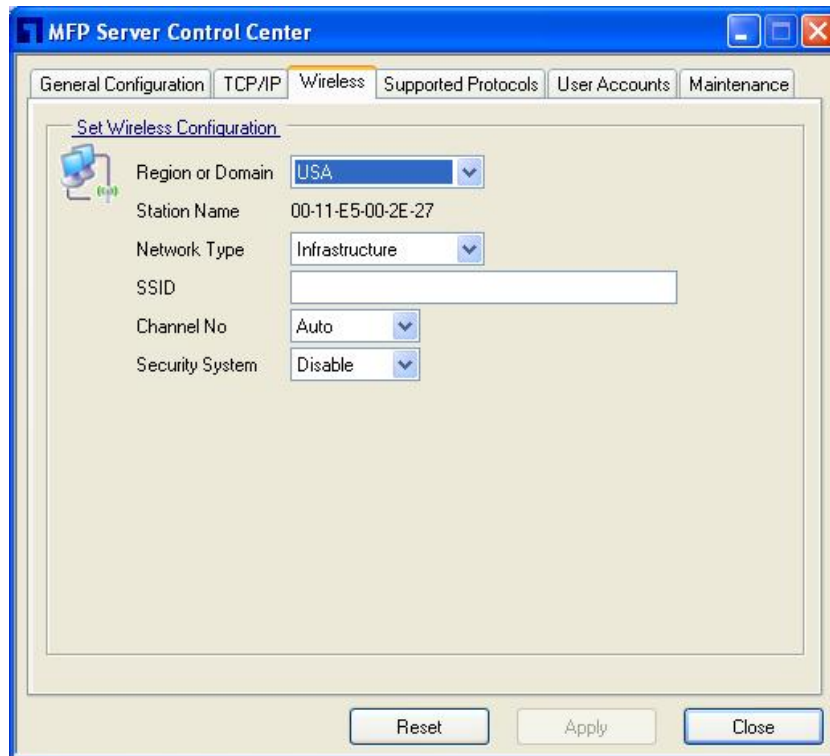

- In order to join an existing wireless network, users have to set the correct network type (infrastructure or ad-hoc), SSID, and the correct security method with the correct key information.
- If the wireless network is secured by WEP64 or WEP128, authentication method, key index, and WEP key must be set correctly.
- If the wireless network is secured by WPA-PSK/TKIP, the shared key must be set correctly.

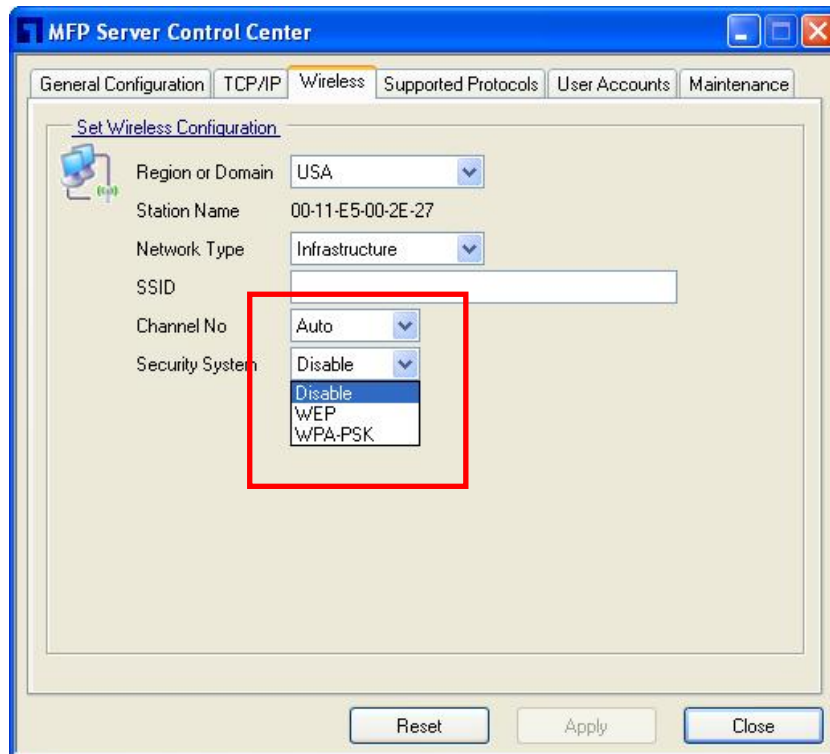

- Click **Apply** to save the settings. And then MFP server will reboot.
- Users have now finished the procedure of setting the wireless parameters.



Note

In infrastructure mode, WUS-3200 searches all channels to join the matched wireless service set. In ad-hoc mode, WUS-3200 searches all channels to join the matched wireless ad-hoc service set too, however, if none are found, WUS-3200 creates that service set in the assigned channel. In ad-hoc mode, WPA-PSK/TKIP is not allowed.

Set Wireless Configuration Using MFP Server's Web Page

- User is able to tell the IP address of MFP server from the server list. Open IE Browser and enter server's IP address or click the Home Icon of MFP Server Control Center utility.

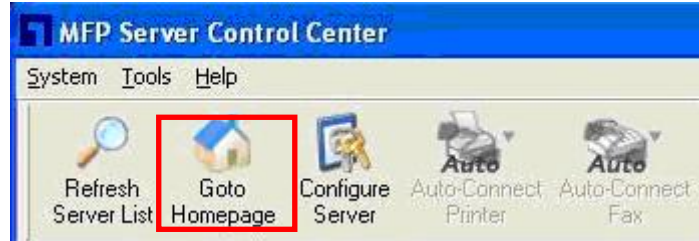

Note

If the wireless parameters are not correct or not set yet, users have to use LAN to access Web Pages.

If the TCP/IP parameters of WUS-3200 are not correct, users have to use MFP Server Control Center to set the TCP/IP parameters first.

- Go to the web page and click **CONFIG** icon.

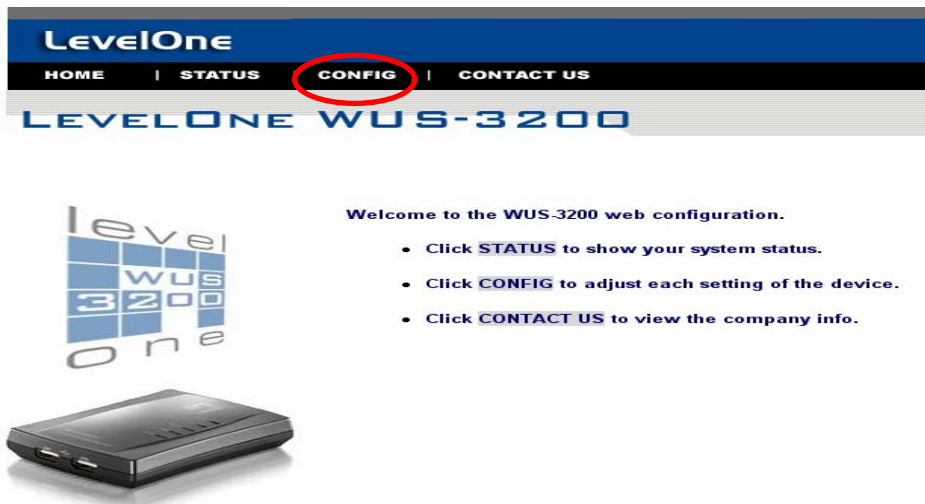

- Administrator login (default: *admin*) and password (default: *admin*).

Login to LevelOne WUS-3200

Administrator	<input type="text" value="admin"/>
Password	<input type="password" value="•••••"/>
<input type="button" value="Login"/> <input type="button" value="Cancel"/>	

- Click **Wireless** icon.
- In order to join an existing wireless network, users have to set the correct network type (infrastructure or ad-hoc), SSID, and the correct security method with the correct key information.

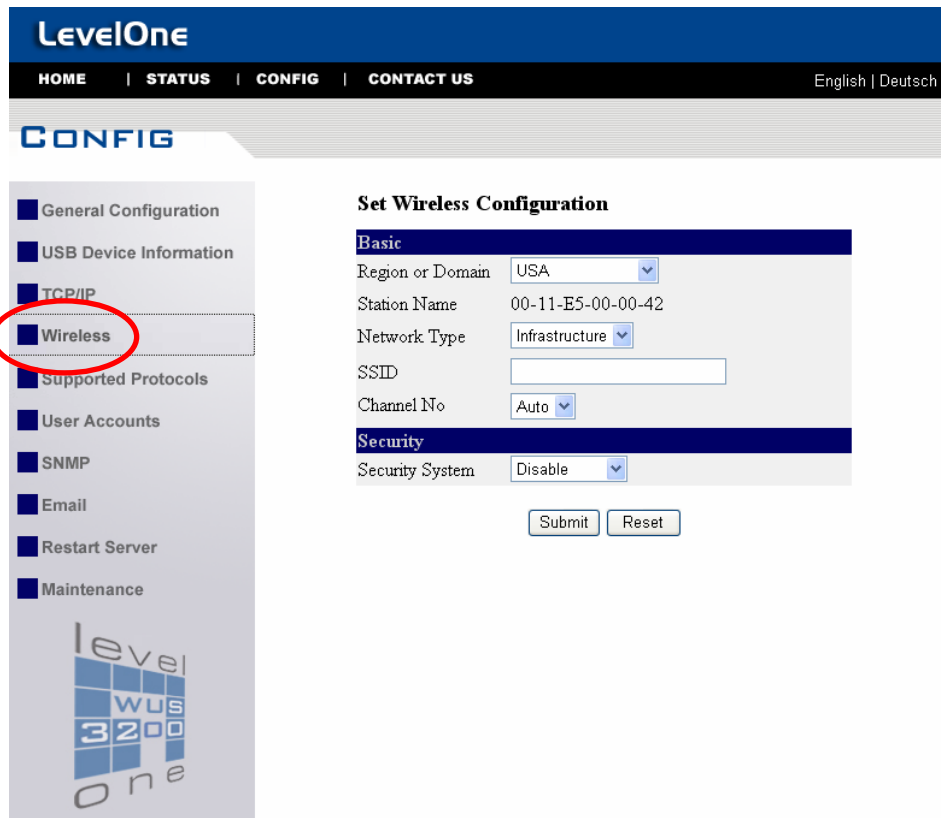

- If the wireless network is secured by WEP64 or WEP128, key index and WEP key must be set correctly.

The screenshot shows the LevelOne web interface. The top navigation bar includes 'HOME', 'STATUS', 'CONFIG', and 'CONTACT US', along with language options 'English | Deutsch'. The main header is 'CONFIG'. A sidebar on the left lists various configuration categories: General Configuration, USB Device Information, TCP/IP, Wireless, Supported Protocols, User Accounts, SNMP, Email, Restart Server, and Maintenance. The main content area is titled 'Set Wireless Configuration' and is divided into 'Basic' and 'Security' sections. In the 'Basic' section, 'Region or Domain' is set to 'USA', 'Station Name' is '00-11-E5-00-00-42', 'Network Type' is 'Infrastructure', 'SSID' is 'LevelOne', and 'Channel No' is 'Auto'. In the 'Security' section, 'Security System' is set to 'WEP'. Under 'WEP Settings', 'Authentication' is set to 'Shared Key', 'Key Size' is '64 Bit (Hex - 10 chars)', and 'Key 3' is set to '1234567890'. 'Submit' and 'Reset' buttons are at the bottom.

- If the wireless network is secured by WPA-PSK/TKIP, the shared key must be set correctly.

The screenshot shows the LevelOne web interface. The top navigation bar includes 'HOME', 'STATUS', 'CONFIG', and 'CONTACT US', along with language options 'English | Deutsch'. The main header is 'CONFIG'. A sidebar on the left lists various configuration categories: General Configuration, USB Device Information, TCP/IP, Wireless, Supported Protocols, User Accounts, SNMP, Email, Restart Server, and Maintenance. The main content area is titled 'Set Wireless Configuration' and is divided into 'Basic' and 'Security' sections. In the 'Basic' section, 'Region or Domain' is set to 'USA', 'Station Name' is '00-11-E5-00-00-42', 'Network Type' is 'Infrastructure', 'SSID' is 'LevelOne', and 'Channel No' is 'Auto'. In the 'Security' section, 'Security System' is set to 'WPA - PSK'. Under 'WPA-PSK Settings', 'Key Format' is set to 'Passphrase (8-63 chars)', 'Pre-Shared Key' is set to '1234567890', and 'Encryption' is set to 'TKIP'. A red note at the bottom states: 'Note: WPA-PSK is not available with ad-hoc networks.' 'Submit' and 'Reset' buttons are at the bottom.

- Click **Submit** to save the new settings. And the MFP server will reboot.
- Users have now finished the procedure of setting the wireless parameters.



Note

In infrastructure mode, WUS-3200 searches all channels to join the matched wireless service set. In ad-hoc mode, WUS-3200 searches all channels to join the matched wireless ad-hoc service set too, however, if none are found, WUS-3200 creates that service set in the assigned channel.

In ad-hoc mode, WPA-PSK/TKIP is not allowed.

3. Using the MFP Server

Introduction to the New Technology of MFP Server

For printers and scanners, there is no industrial standard. In order to support many different models of printers and scanners from various brands, we have adapted the new technology, called “Software Bus”. Software Bus is created to solve the compatibility issue. With the Software Bus technology, it is not necessary to implement printer/scanner drivers. Instead, it relies on printer/scanner drivers that are installed on PCs. In the field of traditional network print server, the common protocols used are, for example, SMB/CIFS, LPR, raw TCP, and IPP. However, in order to reduce cost, many printer vendors produce so-called GDI or host-based printers. For technical reasons, these kinds of printers can not work with the traditional network printer protocols. The Software Bus technology can also deal with this problem. The basic concept and the usage of Software Bus will be introduced in this chapter.

Connect & Disconnect

The new technology of MFP server allows user to use USB printers or USB MFPs as if it were connected directly to the PC, although it is actually connected to the MFP server. The “**Connect**” button is a software operation that simulates an actual plug-in USB device. The “**Disconnect**” operation is a software operation that simulates the disconnection of the USB device.

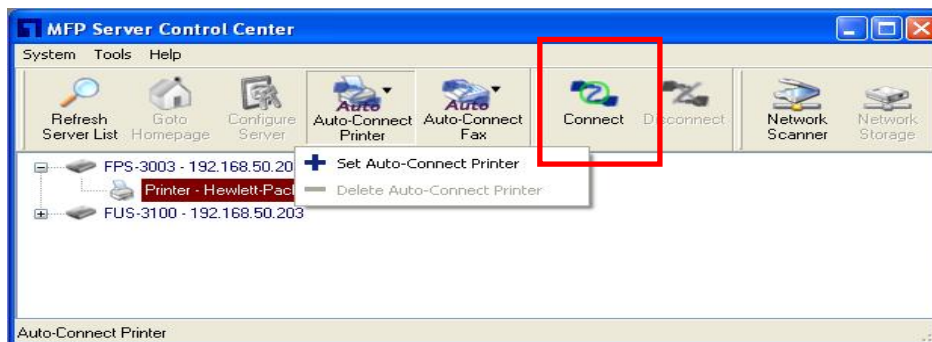

How to Use

Driver Installation

This section will describe how to use the new technology of MFP Server to do driver installation for a USB device. Before the installation, please make sure that the PC can access the MFP server via TCP/IP. The simplest way to do this is using “Control Center” to search for the MFP server on the network and change its IP address to be the same subnet as the PC. If the MFP server and the PC are not in the same TCP/IP subnet, Control Center will show the MFP server in green, as the following figure. User must change the IP address (or using DHCP) of the MFP server so that the MFP server and user’s PC are in the same subnet. When Control Center shows the MFP servers in blue, meaning user can now safely access the MFP server.

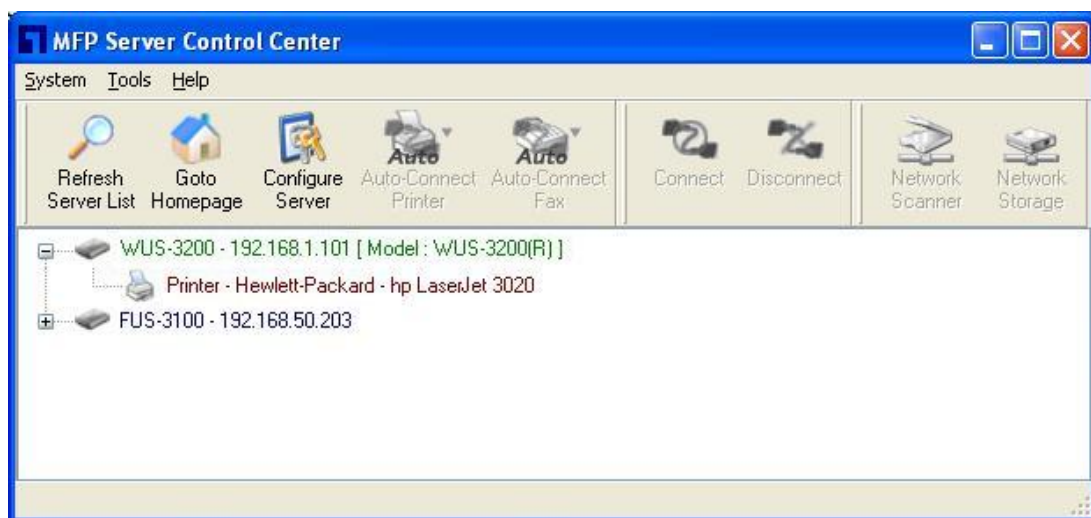

Please see below steps for USB printer or USB Multifunction printer driver installation.

- A. Power on the MFP server and switch on the USB device.
- B. Connect the USB device to MFP server. The LED of the USB port will light-on.
- C. Run the Control Center. In the “MFP Server List” window, user is able to see the host names and IP address of the MFP server (in blue) on the network, as the following figure.

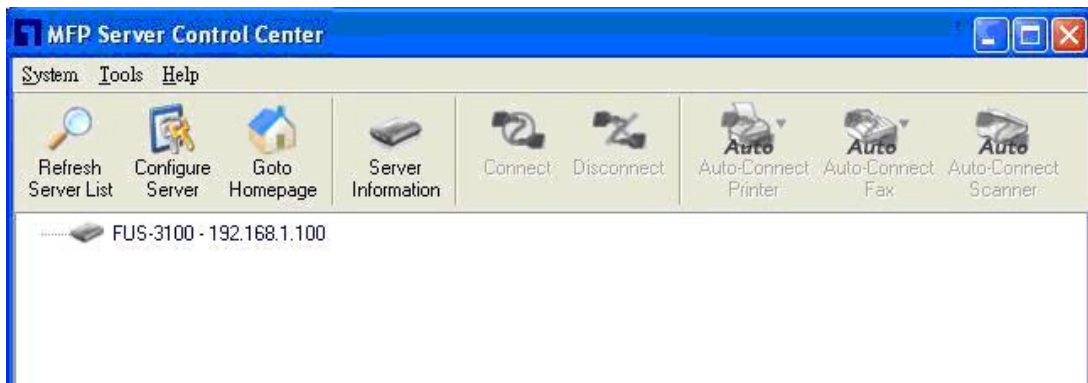

- D. Click the MFP server. Then the USB device attached on the server will be shown.

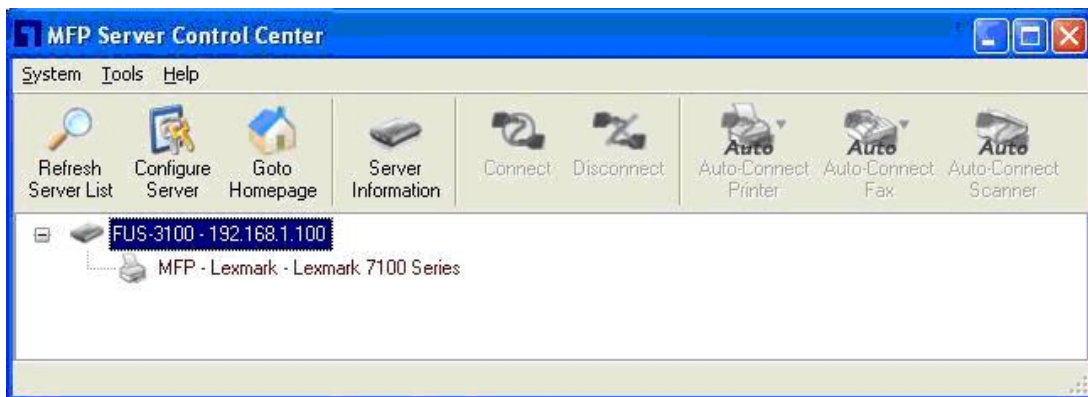

- E. Please prepare to refer to the USB device’s user manual for driver installation.
- F. Click the desired USB device from the Control Center utility list and then click the “**Connect**” button to do the connect operation and get the ownership of the USB device, as the following figure. The computer name of the device owner will be shown at the end of the device.



- G. PC will automatically detect the plug-in of the USB device once user click “**Connect**” button. Please refer to the USB device’s user manual in the driver installation section and proceed to the driver installation.

After complete the USB printer or USB Multifunction printer driver installation, user can now see the newly created devices on the PC. If the USB device is a Multifunction printer (MFP), user can see a new printer and a new scanner from Windows Control Panel.

Set Auto-Connect Printer

After the complete the USB printer or USB Multifunction printer’s driver installation, user can now see a newly created printer in Windows Control Panel “**Printers and Faxes**”. Please follow the below steps to “**Auto-Connect**” configuration.

- A. In the Control Center utility, click the MFP server that has the desired printer (or MFP) attached.
- B. Click the desired printer (or MFP).
- C. Click the “Set Auto Connect” button.

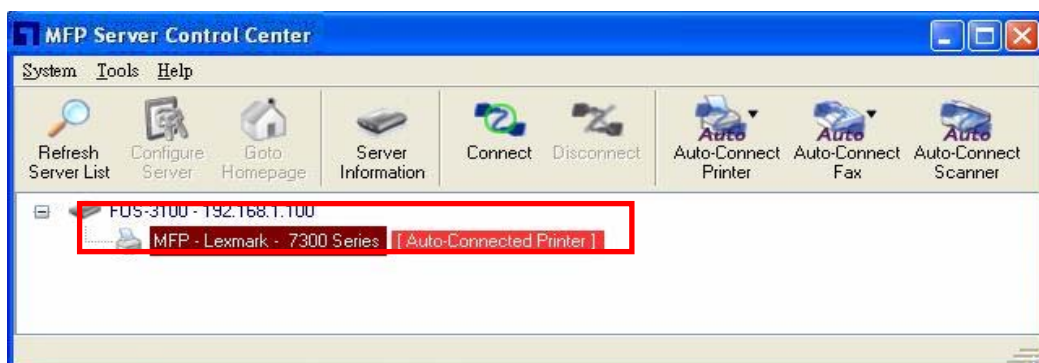
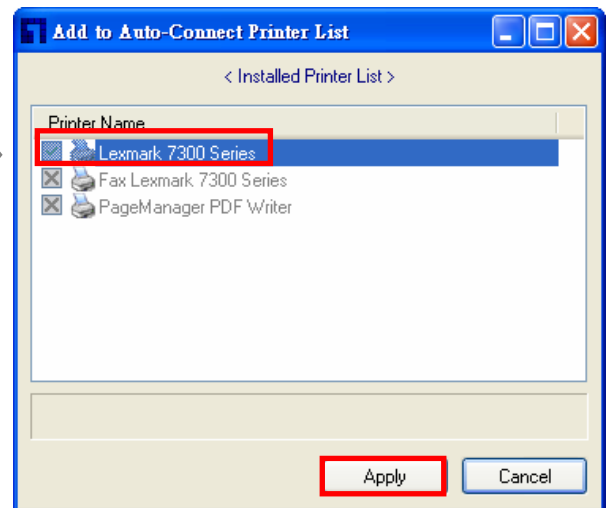
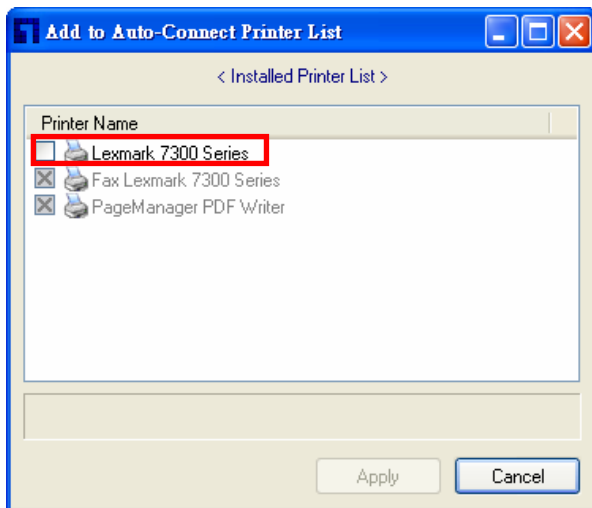

- D. Choose the desired printer. The desired printer must be the Windows printer (this is a logical printer) that matches the printer attached on the MFP server (this is a physical printer). Then click the “Apply” button.
- E. Then, Open control center utility’s “Tools” menu, in the “Auto-Connect Printer List” user can see a newly created item that describes the association between the Windows printer and the physical printer on the server.

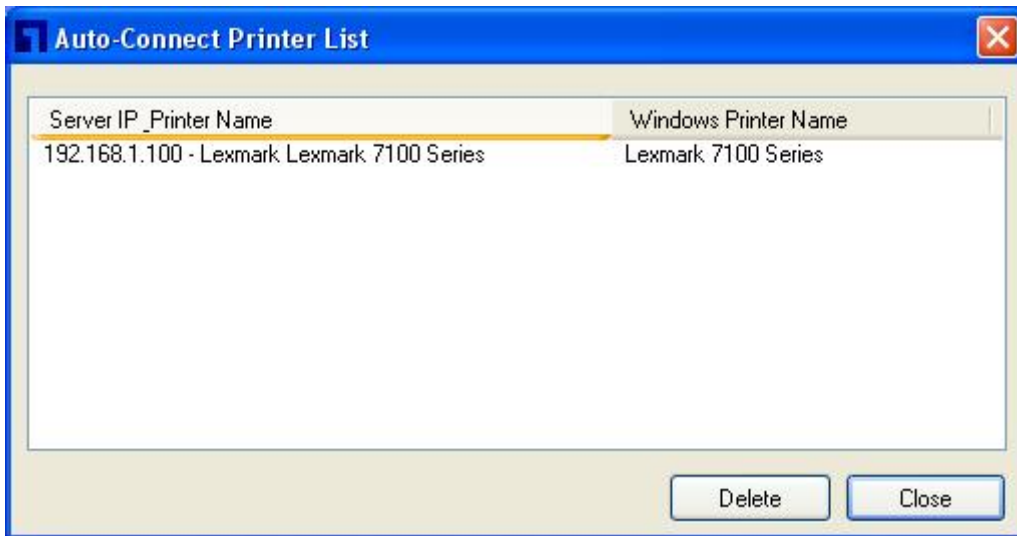

- F. Please try to issue a print job to the desired printer. The Control Center utility will automatically do a connect operation and, once the print job finished, it will automatically do a disconnect operation. This is so-called “Auto Connect / Disconnect” operation.
- G. Even user already properly setup an auto-connect printer, the Control Center utility must be running while a print job is issued. This means that the Control Center utility should be turn on every time user logs in to the Windows. In order to skip this manually operation, user is able make the Control Center utility runs automatically when user has login into Windows. To do this, choose the “Configuration” item in the “Tools” menu. The following window will appear. Click on the check box and then on the “OK” button. Please notice that this feature is enabled by default.



Manual-Connect Scanner

After installed the scanner driver, user is able to see a newly created scanner in the Windows Control Panel's **"Scanners and Cameras"**. Follow the steps below to do a manual-connect scanning.

- A. In the Control Center utility, click the MFP server that has the desired scanner (or MFP) attached.
- B. Click the desired scanner (or MFP)
- C. Click the **"Connect"** button to manually connect the scanner (or MFP)

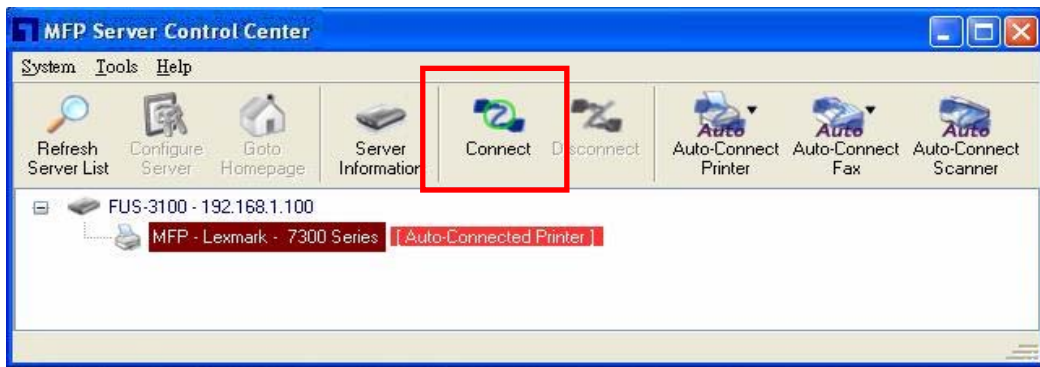

- D. Right-click the scanner icon in the Windows Control Panel's **"Scanners and Cameras"**, and choose **"Get picture using Scanner Wizard"**.

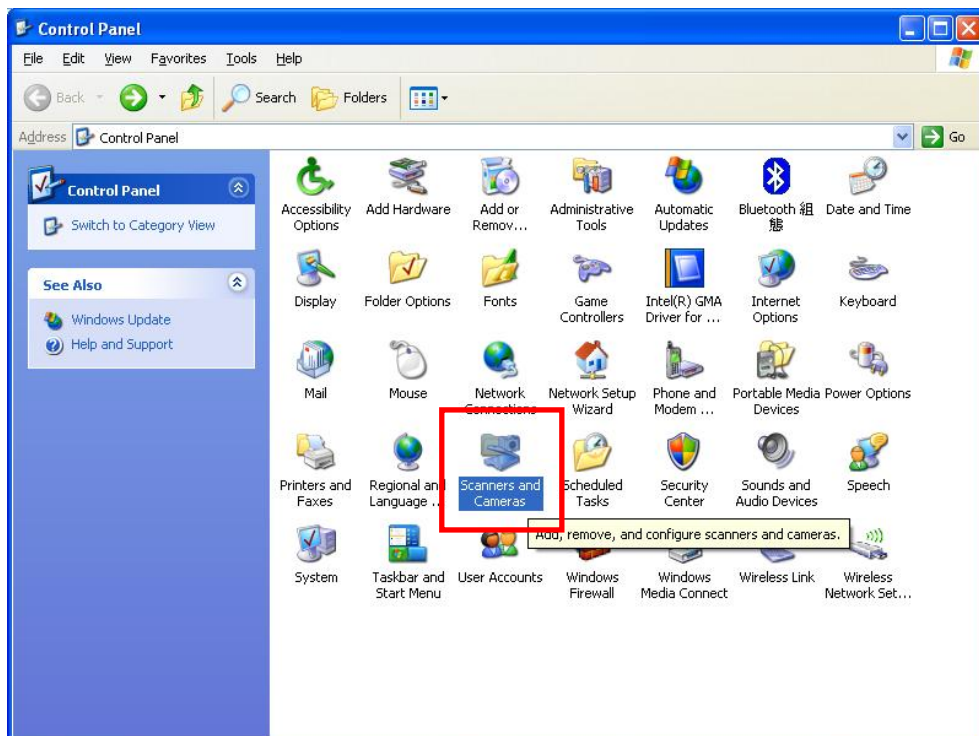

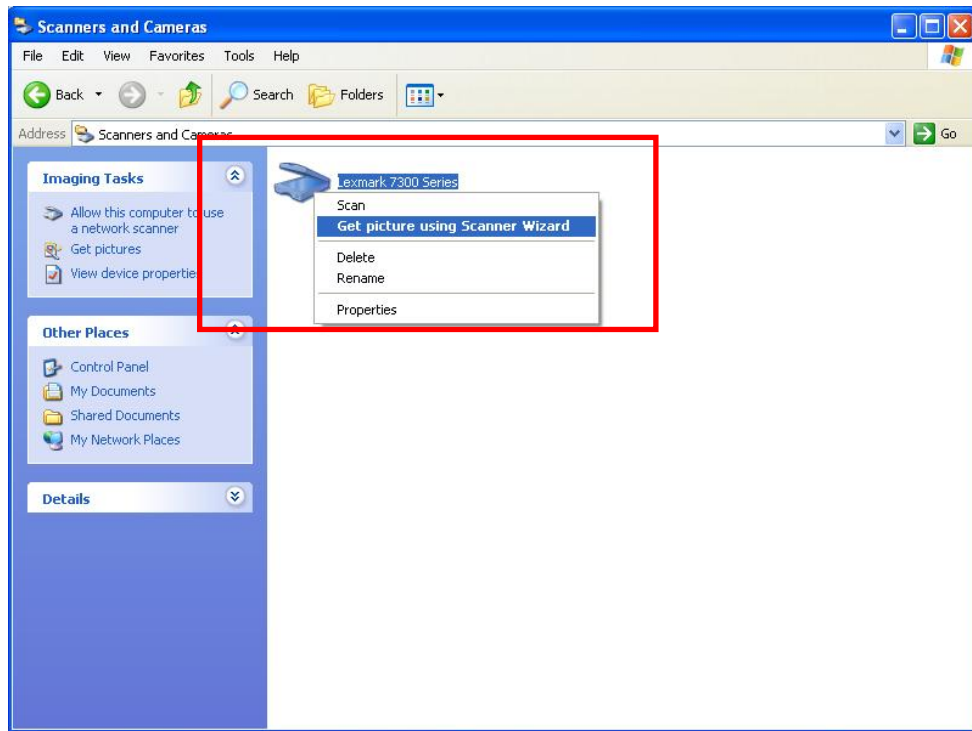

- E. Then the “**Scanner Wizard**” will run. Setup the options as user requested. Then submit the scan job.



- F. When the scanning is completed, click the “**Disconnect**” button in the Control Center utility to release the ownership of the scanner (or MFP).

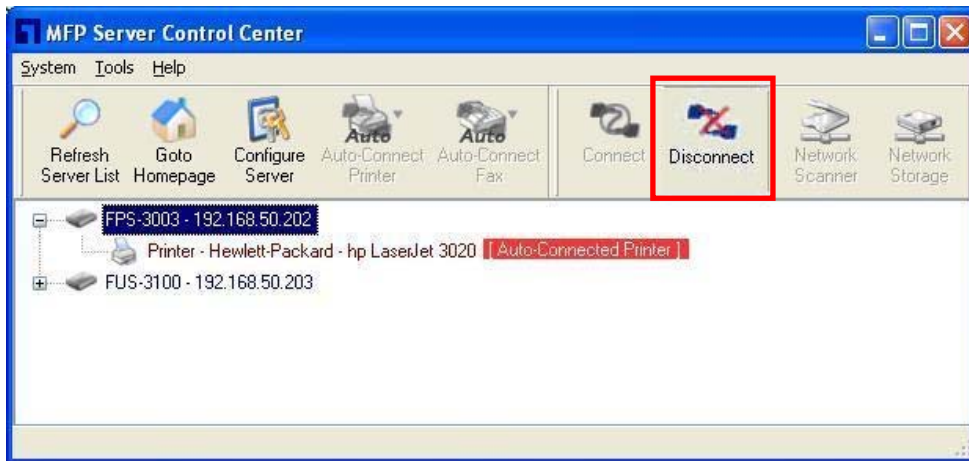

Auto-Connect Scanner

Another way is auto-connect scanning. In Control Center utility, click the desired scanner, and then click "Auto-Connect Scanner" button to select a device that user would like to connect with.

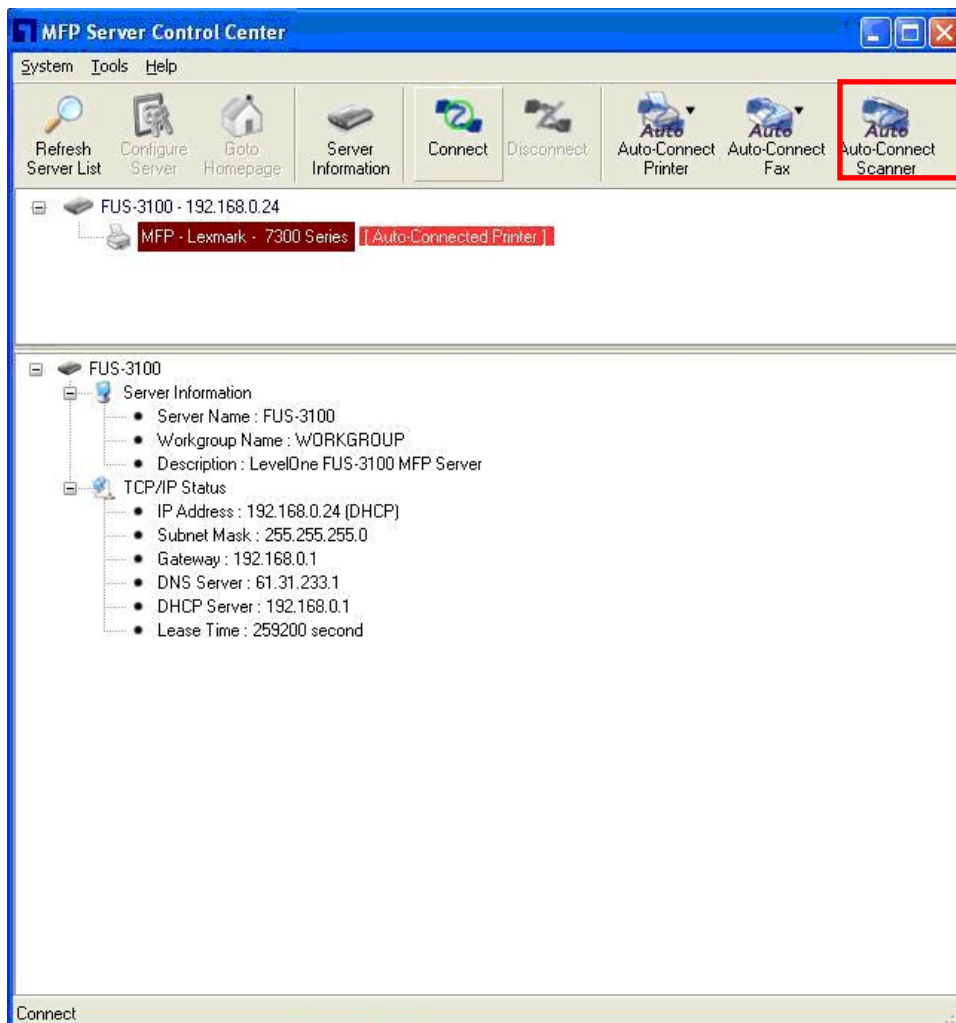



Manual-Connect / Auto-Connect Fax

Some Multifunction printers provide the PC Fax function. After the Multifunction driver installation, User can see a newly created Fax printer in the Windows Control Panel's **“Printers and Faxes”**. Follow the steps below to do a FAX via MFP server.

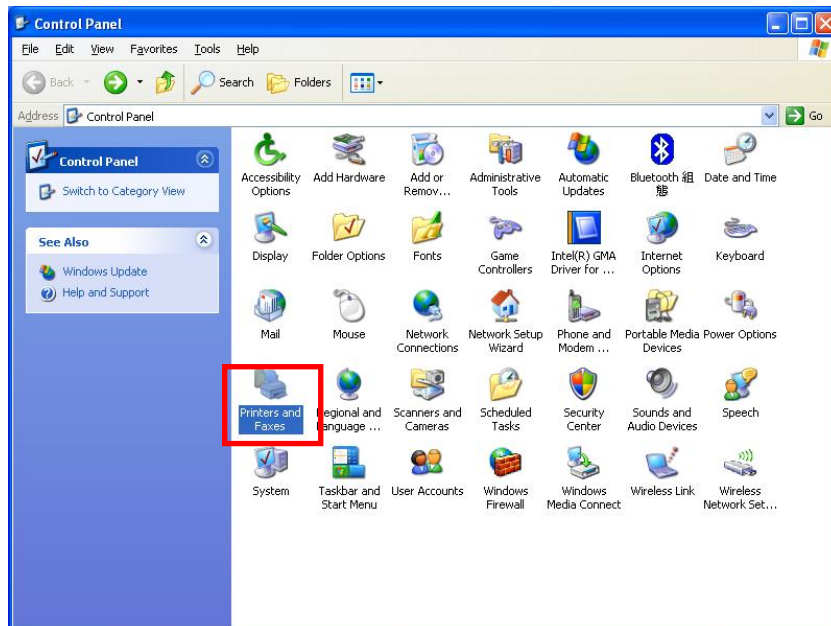

- A. In the Control Center utility, click the MFP server that has the desired MFP attached.
- B. Click the MFP.
- C. Click the “**Connect**” button.
- D. Choose the desired fax printer to do printing.
- E. Then the FAX wizard will show up. Please follow the instructions in MFP’s user manual to send FAX as if the MFP is directly connect to PC.
- F. When the fax job is completed, click the “**Disconnect**” button in the Control Center utility to release the ownership of the MFP.

Another way is auto-connect FAX. The procedures are almost the same as “**Set Auto-Connect Printer**”.

- A. In the Control Center utility, click the MFP server that has the desired printer (or MFP) attached.
- B. Click the desired printer (or MFP).
- C. Click the “**Set Auto Connect**” button. The following figure will appear.

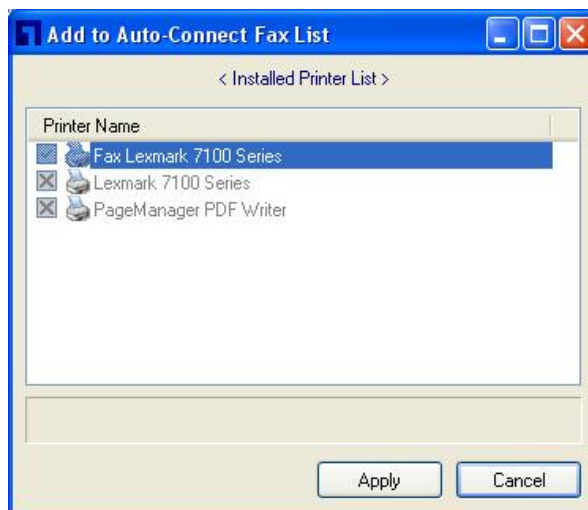

- D. Choose the desired FAX printer. It must be the Windows FAX printer (this is a logical FAX) that matches the FAX attached on the MFP server (this is a physical FAX). Then click the “**Apply**” button.
- E. Then, in Control Center utility, choose “**Auto-Connect Fax List**” in “**Tool**” menu. User can see a newly created item that describes the association between the Windows FAX printer and the physical FAX on the server.

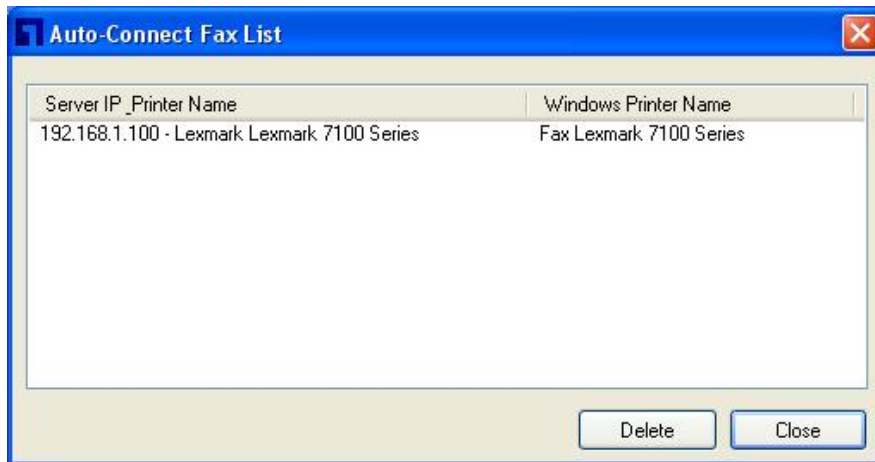

- F. Try to issue a print job to the desired printer, the Control Center utility will automatically do a connect operation and, once the print job (actually this is a FAX job.) finished, it will automatically disconnect operation.

Manual-Connect VS Auto-Connect

It is recommend user not to use “**manual connect/disconnect**” unless certain circumstances. It is recommending user to use “**auto-print/auto-FAX/auto-scan**” so that Control Center utility will automatically connect/disconnect devices when required. This operation works fine in most of the cases. However, there are some cases that automatic connect/disconnect might not work. In these cases, user should use “**manual connect/disconnect**” to do print/scan/FAX. Once **manual connect** function job completed, please remember to do a **manual disconnect** after using the MFP.

Take HP OfficeJet 5510 as an example. If user would like to use vendor-supplied utility to send FAX with HP OfficeJet 5510, the “**auto-connect FAX**” can not work for some technical reason. In this case, users have the following alternative to solve the problem.

- A. Use other applications like Microsoft Word, or Photoshop to send FAX. “**Auto-connect FAX**” can work well with most general applications.
- B. Do a **manual connect** on HP OfficeJet 5510. Then begin to send FAX using vendor-supplied utility. After the operation, do a **manual disconnect**.

In summary, users should use manual connect/disconnect only when doing driver installation and when auto connect/disconnect can not work well.

Limitations

There are still some limitations for using the new technology of MFP Server.

- A. Supports Windows 2000/XP/Vista; **Windows 98/ME is not supported.**
- B. **Only one PC can get the ownership of the same USB device at the same time.**

Connecting Period for Auto Connect and Manual Connect

Please refer to below description for device connecting period.

Auto Connect with Printer: Automatically disconnect when printing job is completed.

Auto Connect with Scanner: Automatically disconnect when printing job is completed.

Auto Connect with Fax Machine: Automatically disconnect 3 minutes after Fax completed.

Manual Connect with Printer: Automatically disconnect, 1 hour after printing completed.

Manual Connect with Scanner: Automatically disconnect, 1 hour after scanning completed.

Manual Connect with Fax Machine: Automatically disconnect, 1 hour after Fax completed.

Manual Connect with File Server: Automatically disconnect, 24 hours after file access.



Note

Only one PC can get the ownership of the same USB device at the same time. For manual connectivity, please remember to disconnect after jobs completed and release the ownership for other users to use.

4. The Control Center Utility

This chapter describes how to use the Control Center Utility.

Installing Control Center Utility



1. Insert the Product CD into the CD-ROM. The Autorun screen will appear.
2. Select the model and click **Utility** to begin the utility installation.
3. Follow the on screen instruction to step through the installation.

Using the Control Center Utility

Using Tools of Control Center Utility

User may use the following tools to use the MFP server:



- *Refresh Server List*  : auto search for the existing MFP servers in the network
- *Configure Server*  : configure the MFP server
- *Goto HomePage*  : configure the MFP server via IE browser.

Note: User can also right-click the mouse button on the MFP server to get the “**Configure Server**” and “**Goto HomePage**” functions.

Note: User can also double-click on the MFP server to grand the “**Configure MFP Server**” function.

Displaying MFP Server Status

User may start the Control Center utility and select the MFP Server to see its status which includes Host Information, TCP/IP Status.

Setting up MFP Server Configuration

Click on “**Configure Server**” button to setup the select MFP server. Then enter the administrator ID and password to login.

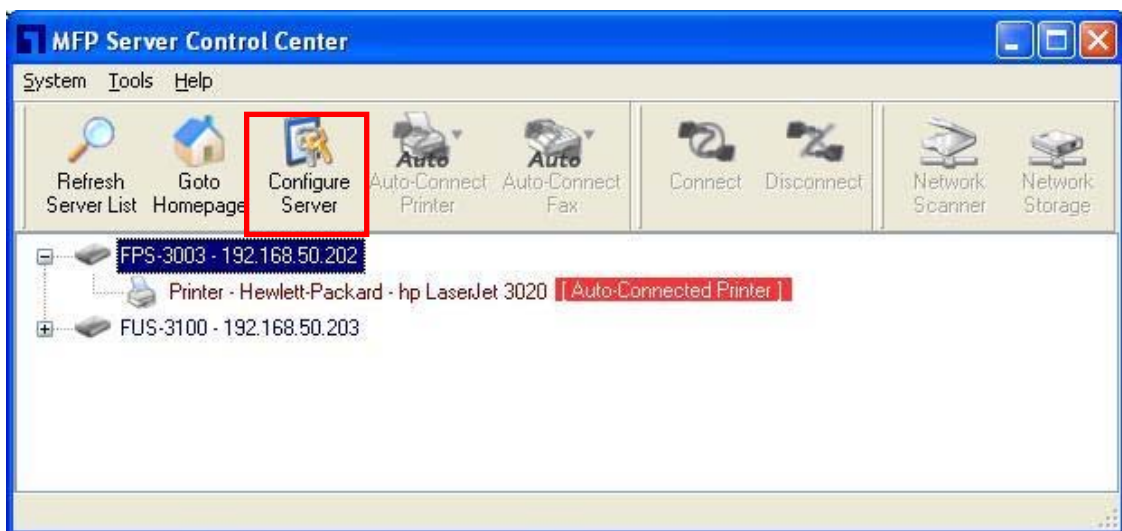

General Configuration

- ◆ **Set Host Information:** Set basic host information for the MFP server:
 - Server Name*
 - Workgroup*
 - Description*

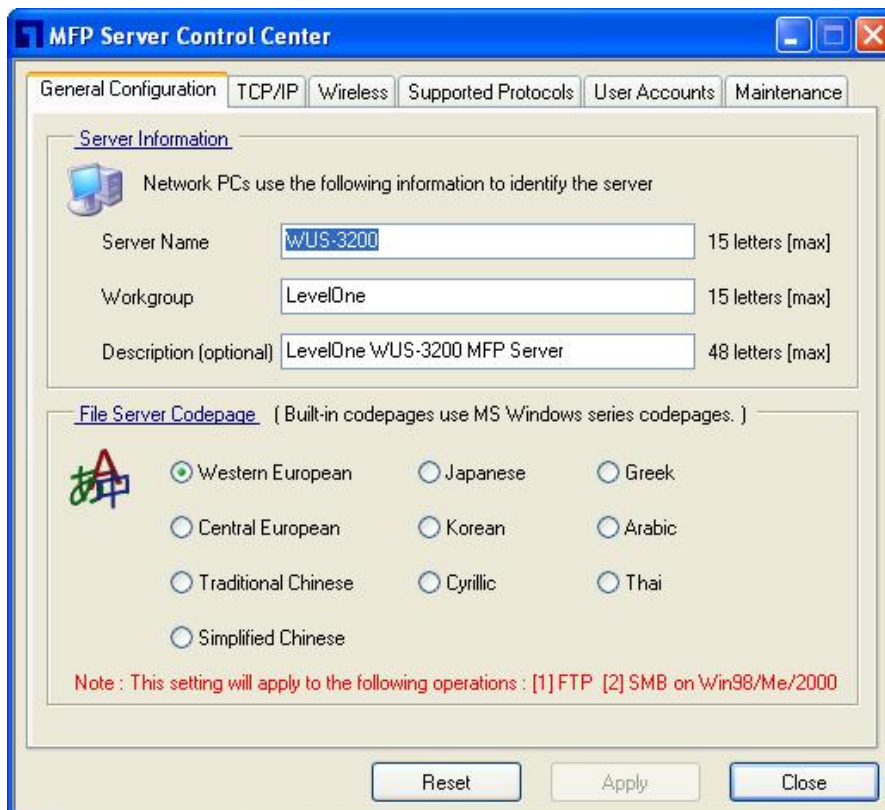

TCP/IP: Setup the MFP Server's TCP/IP configuration to connect TCP/IP network. Please refer to **Chapter 3 Basic Installation** for more details.

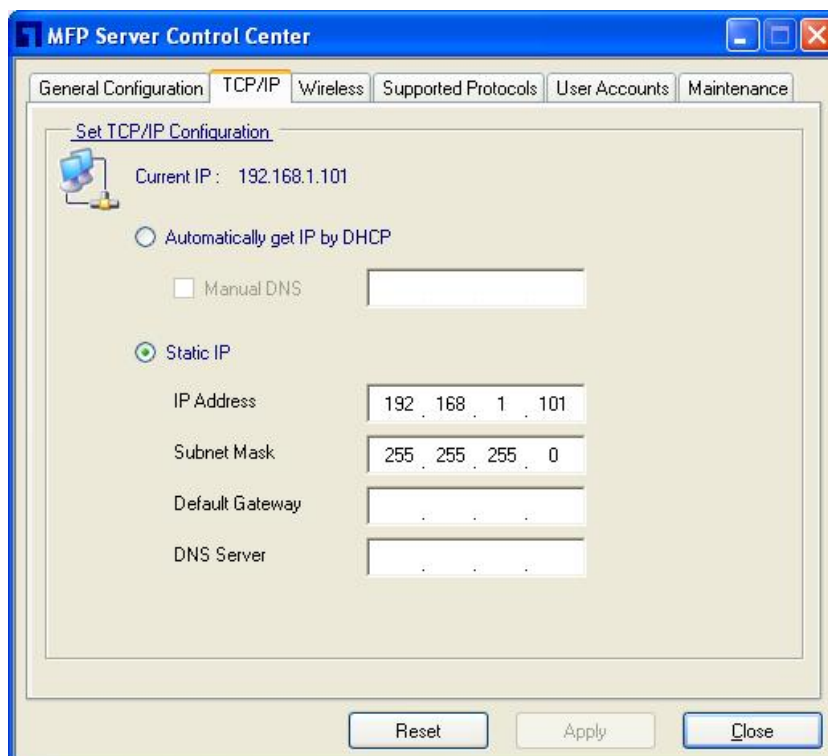

User Accounts: Administrator is able to change administrator name and its password. If user forgot the administrator login name and password, it then must perform Restore Factory Default action, please refer to the chapter “**Restore Factory Defaults**”. In addition, administrator user is allowed to create user name and password along with corresponding permission for file sharing function. For detail description, please refer to below “**User Account List**”.

Set Administrator

New Administrator: enter the desired administrator name.

New Password: enter the desired password.

Retype Password: re-enter the password to double confirm.

User Account List

User Name & Password: Administrator is allowed to create up to 25 user accounts with corresponding permissions.

Read Only: Users login with “**Read Only**”; it only allows accessing and retrieving the files in the file server. This user account does not have the right to modify files in the file server. For File Server functionality, please refer to **Chapter 6 File Server**.

Read-Write: Users login with “**Read-Write**” is empowered to modify files in the file server..

The screenshot shows the 'User Accounts' tab in the MFP Server Control Center. It features a 'Set Administrator' section with fields for 'New Administrator' (containing 'admin'), 'New Password', and 'Retype Password', along with a 'Set' button. Below this is the 'User Account List' section, which includes a note '(Note : Allows up to 25 user accounts.)', input fields for 'User Name' and 'Password', a 'Permission' dropdown menu (currently showing 'Read-Write'), and 'Add', 'Delete', and 'Reload' buttons. A table below the dropdown shows a single entry with columns for '#', 'User Name', 'Password', and 'Permission'. The table content is partially obscured by the dropdown menu.

#	User Name	Password	Permission
			Read-Write

Maintenance: Using Maintenance tool page to restart, restore factory defaults or upgrade latest firmware for the MFP Server. The latest firmware can be found and download from LevelOne website at www.level1.com .

- ◆ **Restart Server:** click this button, the MFP Server will restart.
- ◆ **Factory Default:** click this button, the MFP Server will restore factory default values.
- ◆ **Download New Firmware:** click this button to download new firmware.
- ◆ **Upgrade Firmware:** click **Open** to locate the firmware file. Click **Upload** to upload the firmware into MFP Server.

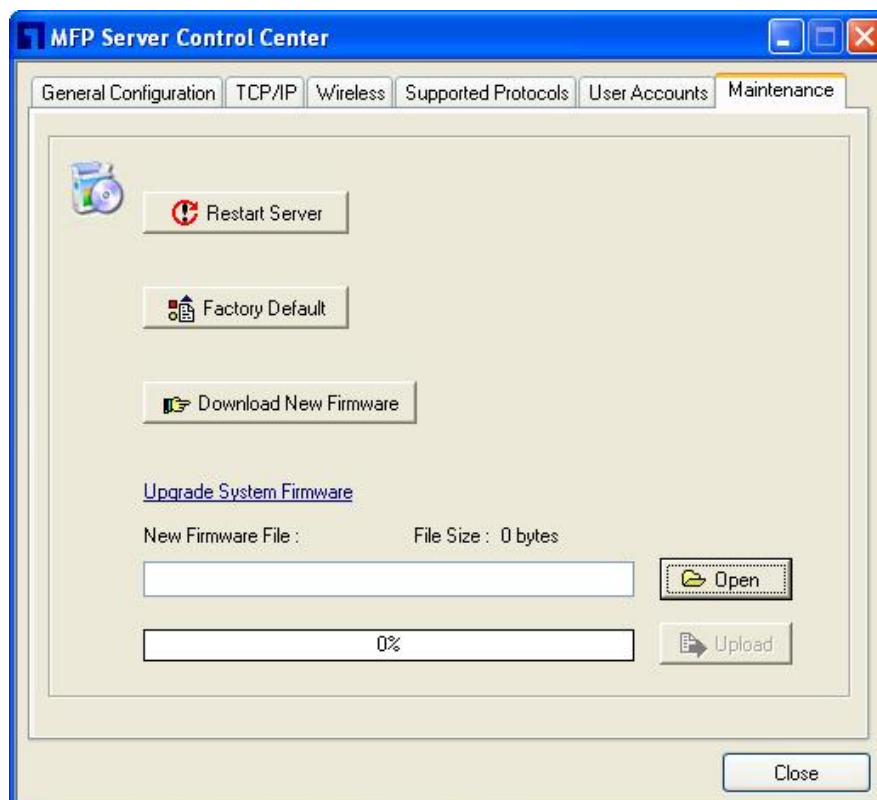

Quitting the Control Center Utility

The Control Center Utility doesn't really quit if user clicks the "X" box (close box) at the top right corner of the window. Instead, it just minimizes itself to the system tray. There are two ways to really shut down the Control Center Utility. The first way is choosing "**Exit**" item in the "**System**" menu in the Control Center Utility.

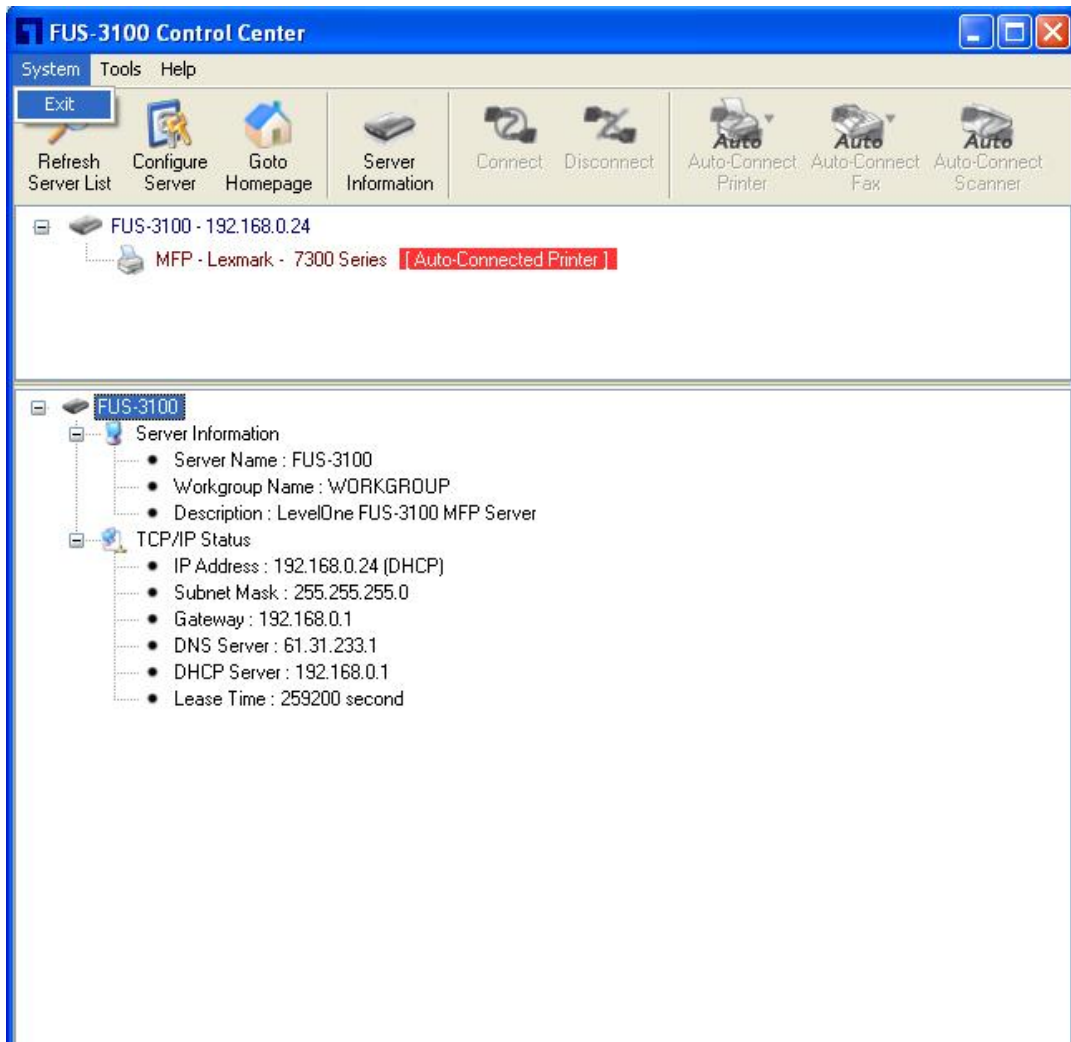

The second way is right-clicking the icon of the Control Center Utility in the system tray and choosing the "**Exit**".



5. File Server

This chapter describes the file server function of the MFP Server which allows USB storage devices to be shared across a network by using SMB: NetBIOS over TCP/IP and FTP protocol.

Preliminary

1. This product supports a file format of FAT12/16/32 and NTFS. However, the “**write**” operation on NTFS only supports in NetUSB mode. Please refer to the **Storage Access Mode**.
2. Please notice that LevelOne is not responsible for the loss or corruption of data in memory devices, including hard disk; LevelOne also not responsible for the leak, manipulation, loss, or corruption of data in memory devices connected to the MFP Server after unauthorized access.
3. In order to use the USB Mass Storage device connected to the MFP Server, the SMB protocol or FTP protocol must be set up.
4. This product does not support to magnet optical drive devices such as CD/DVD.
5. FPS-3003 / WUS-3200 are allowed shared two USB storage devices over the network in Windows through the USB ports.
6. MFP Server does not support the USB devices through USB hub.

Storage Names

The local drives of the two storages in USB1 port and USB2 port are named as USBx_DxPx, where USBx represents the USBx port, Dx represents the the x-th Disk and Px represents the x-th partition.

Connecting USB Mass Storage to the Server

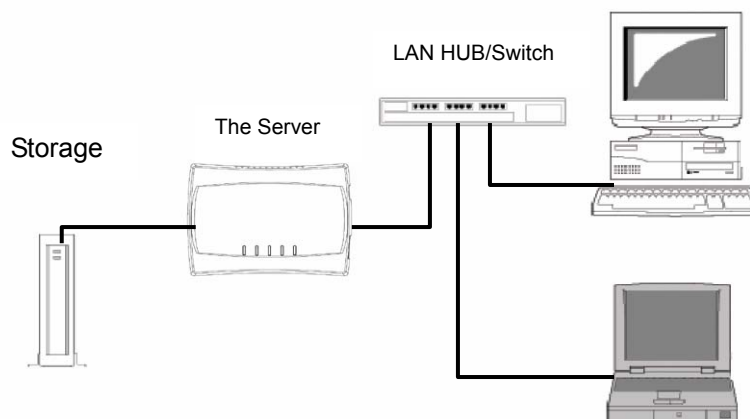

Supported Codepages

What is codepage?

Used by the system to encode and interpret string characters. Codepage formats are not the same for each language. Some languages, such as Japanese have multibyte characters, while others, such as English and German, need only one byte to represent each character.

Filename Encoding of FAT File System

This is known as an 8.3 file name, a short file name using codepage encoding. The FAT file system also supports file names that can be up to 255 characters long. This is known as a long file name using Unicode (UTF-16) encoding.

When do you need to configure codepage?

The Server supports Windows codepages. If users want to communicate files using FTP client tool or SMB on Windows 2000 with the MFP Server, they have to set their MFP Server codepage to be same as the codepage that their Windows PC is using.

1. FTP
2. SMB on Windows 2000

Configuring the Server's Codepages

Users can use the following methods to set the MFP Server's codepage.

Using Control Center Utility

1. Start Control Center Utility and Auto-searching MFP Server window will appear.
2. If the tool finds the MFP Servers in your local area network, then you have to select one of the Servers from the Server List.
3. Double click the highlight list and enter the administrator (default: *admin*) and password (default: *admin*).
4. After you have logged in successfully, setting **General Configuration** dialog appears.

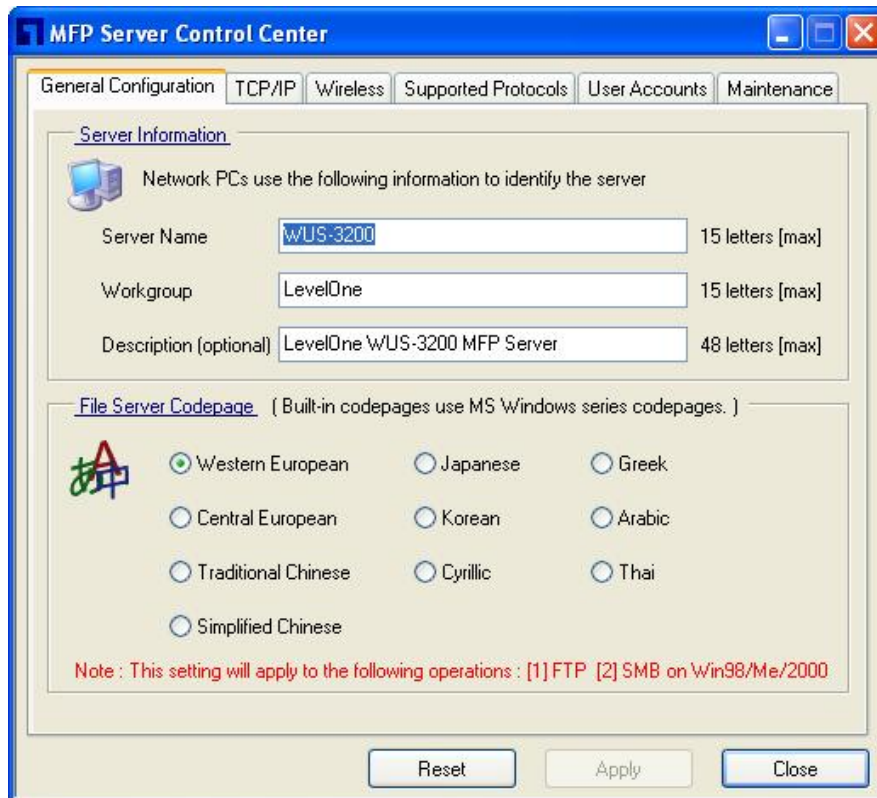

5. Select the codepage form **File Server Codepage** box and click **Apply**.

Using MFP Server's Web Pages

1. Go to the web page, click **CONFIG**
2. Login your administrator (default: *admin*) and password (default: *admin*).
3. After you have logged in successfully, setting **General Configuration** dialog appears.

File Server Code Page

- Western European
- Central European
- Traditional Chinese
- Simplified Chinese
- Japanese
- Korean
- Cyrillic
- Greek
- Arabic
- Thai

* Built-in codepages use MS Windows series codepages.
* This setting will apply to the following operations :
1. FTP (File Transfer Protocol)
2. SMB on Windows98/ME/2000

4. Select your codepage form **File Server Codepage** box and click **Apply**.

Adding USB Mass Storages to Network with Security

User can use the following protocols to share USB Mass Storages with user level security in network:

- SMB/CIFS: NetBIOS over TCP/IP
- FTP

The protocols are shown in **Supported Protocols** box of the Control Center utility or the MFP Server's web pages.

Setting up File Server Using the Control Center Utility

1. Start the Control Center Utility and Auto-searching MFP Server window will appear.
2. If the tool finds multiple Servers in your local area network, then you have to select one of the Servers from the Server List.
3. Double click the highlight list and enter the Server's administrator (default: *admin*) and password (default: *admin*).
4. After you have logged in successfully, click **Supported Protocols**.

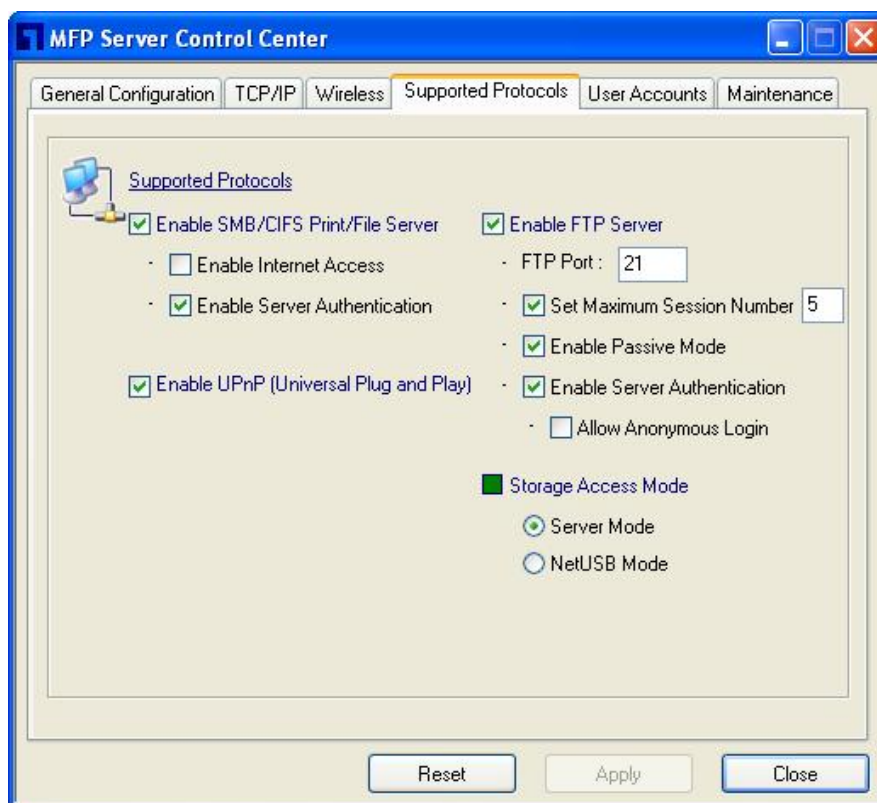

5. Set up File Server Configuration:

Set SMB/CIFS Print/File Server

- **Enable SMB/CIFS Print/File Server:** select the item, if you want to support SMB/CIFS print/File server.
- **Enable Internet Access:** uncheck the box; accessing SMB/CIFS server through the Internet will be disabled. If user selects the item, it will allow Internet users to

access the storage using the SMB/CIFS protocol.

- **Enable Server Authentication:** Select the item, if user wants to share the storage with user level security which requires user name and password to login. If this function is disabled, the storage will be shared without any security.

Set FTP Server:

- **Enable FTP Server:** select the item, if user wants to support FTP server.
- **FTP port:** enter the desired FTP port. The default value is 21.
- **Maximum Session Number:** select the item and fill in desired number.
- **Enable Passive Mode:** select the item, if user wants to allow FTP server can accept passive mode command.
- **Enable Server Authentication:** check the box, if user wants to share the storage with user level security which requires user name and password to login. If uncheck the item, the storage will be shared without security access.
- **Allow Anonymous Login:** select the item, it will allow user “anonymous” to login the FTP server with read-only permission and the Server will not check the password. If the box is unchecked, the FTP server will not support anonymous login function.
- **Storage Access Mode:** To use FTP and SMB/CIFS to access storage, please set the storage access mode to the server mode. For the NetUSB mode, please refer to chapter 9.

Setting up File Server Using Web Pages

1. Go to the web page, click **CONFIG**
2. Login your administrator (default: *admin*) and password (default: *admin*).
3. After you have logged in successfully, click **Supported Protocols**.

Set Supported Protocols

TCP/IP

Enable LPR Printing

Enable IPP Printing

Enable Raw TCP/JetDirect Printing

- TCP Port (to USB1)

- TCP Port (to USB2)

Enable SMB/CIFS Print/File Server

- Enable Internet Access

- Enable Server Authentication

Enable FTP Server

- FTP Port

- Set Maximum Session Number

- Enable Passive Mode

- Enable Server Authentication

- Allow Anonymous Login

Enable SANE Server

- SANE Port

Enable UPnP (Universal Plug and Play)

Storage Access Mode

Server Mode NetUSB Mode

4. Set up File Server Configuration:

Set SMB/CIFS Print/File Server

- **Enable SMB/CIFS Print/File Server:** select the item, if you want to support SMB/CIFS print/File server.
- **Enable Internet Access:** uncheck the box; accessing SMB/CIFS server through the Internet will be disabled. If user selects the item, it will allow Internet users to access the storage using the SMB/CIFS protocol.
- **Enable Server Authentication:** Select the item, if user wants to share the

storage with user level security which requires user name and password to login. If this function is disabled, the storage will be shared without any security.

Set FTP Server:

- **Enable FTP Server:** select the item, if user wants to support FTP server.
- **FTP port:** enter the desired FTP port. The default value is 21.
- **Maximum Session Number:** select the item and fill in desired number.
- **Enable Passive Mode:** select the item, if user wants to allow FTP server can accept passive mode command.
- **Enable Server Authentication:** check the box, if user wants to share the storage with user level security which requires user name and password to login. If uncheck the item, the storage will be shared without security access.
- **Allow Anonymous Login:** select the item, it will allow user “anonymous” to login the FTP server with read-only permission and the Server will not check the password. If the box is unchecked, the FTP server will not support anonymous login function.
- **Storage Access Mode:** To use FTP and SMB/CIFS to access storage, please set the storage access mode to the server mode. For the NetUSB mode, please refer to chapter 9.

Using Shared Storages by SMB/CIFS Method for Windows

1. Connect a USB storage device to this product.
2. Select **My Network Places**
3. Click **Display the Computers of Workgroup**
4. Double click **Microsoft Windows Network** icon.
5. Double click the **Workgroup** that the Server belongs to. The default Workgroup name is “*WORKGROUP*”. Please refer to Control Center utility or the Server’s web pages.
6. If the Workgroup name of the Server in Microsoft Windows Network cannot be found, please select **Search for Computer...** in **My Network Places** and enter the Server Name of the Server to discover it.
7. Double click the Server Name icon.
8. If you clear **Enable SMB/CIFS Print/File Server Authentication in Supported Protocols**, you login to the SMB server without requiring authentication; otherwise you

have to enter user name and password to login to the Server. You can add user name and password in **User Account** box by the Control Center or the Server's Web page.



Note

If you use SMB on Windows 98 SE/ME, you must login to your Windows 98 SE/ME using the same user name as in the Server's User Account.

- The shared folders will be listed as USB1_DyPz, and USB2_DyPz where Dy represents the y-th disk and Pz represents the z-th partition with respect to USB1 port and USB2 port.
- Perform Open, Paste, Remove or Copy the files to the shared folders.



Note

Another way to use shared storages by SMB/CIFS method: In Control Center utility, click the "Network Storage" button, as the following figure.



Using Shared Storage by FTP Methods for Windows

Use Microsoft IE to the shared USB Mass Storages

1. Open Microsoft IE
2. In **Web Address List**, enter command: “ftp://Server’s *Server Name*” or “ftp://Server’s *IP address*”. If you have changed the default FTP port: 21 to the new value, you have to add the new port number in the tail of command as “ftp://Server’s *Server Name*: *ftp port*” or “ftp://Server’s *IP address*: *ftp port*”.
3. If user sets the **Enable Server Authentication in FTP server protocol settings** user must enter user name and password to login to the Server; if set **Allow Anonymous Login**, user can use the user name “anonymous” to login with Read-only permission. If user clear Server authentication, there is no username or password request for login into the Server. User is allowed to add user name and password in **User Account** box by the Control Center Utility or the Server’s Web pages.
4. The shared folders will be listed in IE.
5. Perform Paste, Remove or Copy the files to the shared folders.

Use Microsoft Dos’s FTP client

1. Enter Dos command as “ftp”
2. Enter “*open server’s Server Name*” or “*open server’s IP address*”. If you have changed the default FTP port : 21 to the new value, you have to add the new port number in the tail of command as “*open server’s Server Name ftp port*” or “*open server’s IP address ftp port*” .
3. If user sets the Enable Server Authentication in FTP server protocol settings user must enter user name and password to login to the Server; if set Allow Anonymous Login, user can use the user name “anonymous” to login with Read-only permission. If user clear Server authentication, there is no username or password request for login into the Server. User is allowed to add user name and password in User Account box by the Control Center Utility or the Server’s Web pages.
4. Perform FTP commands to use this FTP server.

6. MFP Server's Web Pages

Introduction

The Server runs the daemon of http server, <http://serverIP> on TCP port: 80. Users may use the web pages to see the Server's system status and configure the Server.

Using the Server's Web Pages

Displaying Server Status

The status of Server Information and TCP/IP.

The screenshot shows the LevelOne web interface. At the top, there is a blue header with the 'LevelOne' logo and navigation links for HOME, STATUS (which is highlighted), CONFIG, and CONTACT US. On the right side of the header, there are language options for English and Deutsch. Below the header, the main content area is titled 'STATUS'. On the left side of this area, there is a vertical sidebar with the 'level' logo and 'FUS 3100' text. The main content area displays 'System Status' with a '[Reload]' link to its right. Below this, there are two sections: 'Machine Information' and 'TCP/IP Status'. The 'Machine Information' section lists: Firmware Version: 2.23, Machine Model: FUS-3100, and Server Name: FUS-3100. The 'TCP/IP Status' section lists: IP Address : 192.168.1.100 (dhcp failed), Subnet Mask : 255.255.255.0, Gateway : 255.255.255.255, DNS Server : 255.255.255.255, DHCP Server : 0.0.0.0, and Lease Time : 0 second.

Setting up Server Configuration

To set up the Server configuration, the system will request user to enter administrator (default: *admin*) and password (default: *admin*) to login.

■ General Configuration

- ◆ **Set Host Information:** You can set some basic host information for using the server:

- Server Name:* the name to represent the Server

- **TCP/IP:** You have to set the Server's TCP/IP configuration to connect TCP/IP network. Please see Chapter 3 Basic Installation for more details.

- **User Accounts:** You can change administrator name and password. If you forgot administrator name and password, you must perform Restore Factory Default action by plugging in the power adaptor while pressing the Init button. Please refer to the chapter "Restore Factory Defaults".

- ◆ **Set Administrator**

- New Administrator:* enter your desired administrator name.

- New Password:* enter your desired password.

- Retype Password:* confirm your previous password typing.

Set User Account

Set Administrator		Submit	Reset
New Administrator	<input type="text" value="admin"/>	15 letters [max]	
New Password	<input type="text"/>		
Retype Password	<input type="text"/>		

- **Restart Server:** click this button, the Server will restart.

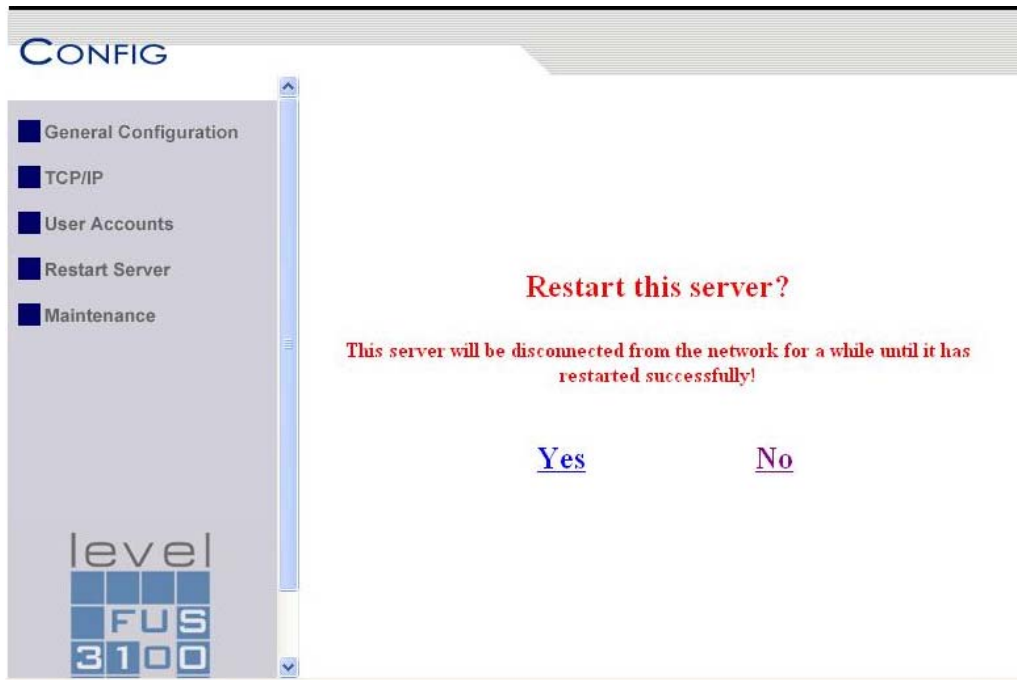

- **Maintenance** If you want to restore factory default values of the Server and upgrade new firmware, you can use the Maintenance tool.
 - ☑ **Factory Default:** click this button, the Server will restore factory default values.
 - ☑ **Download New Firmware from Website:** click this button to download new firmware or user software from this product's public website.
 - ☑ **Upgrade Firmware:** click **Open** to find the firmware file to be upgraded. Click **Upgrade** to upload the firmware into the Server.

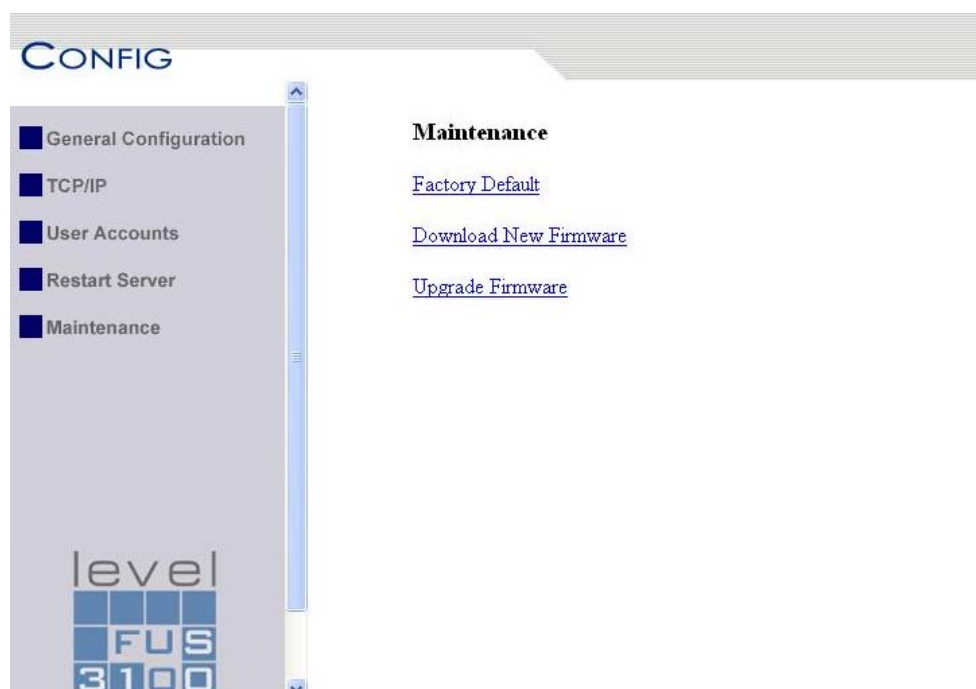

7. Upgrade Firmware

This chapter describes how to upgrade firmware. Please follow one of the following Procedures.

Procedure A: Using the Control Center Utility

1. Open Control Center. It will automatically search the existing Servers and display their statuses.
2. Select the Server that you want to upgrade the firmware. Double click the selected Server and enter Administrator (default: *admin*) and Password (default: *admin*).
3. Select the **Maintenance** button.
4. Click **Open** to find your new firmware file and click **Upload** to start upgrading the firmware.
5. Wait for 15 seconds for system reboot.

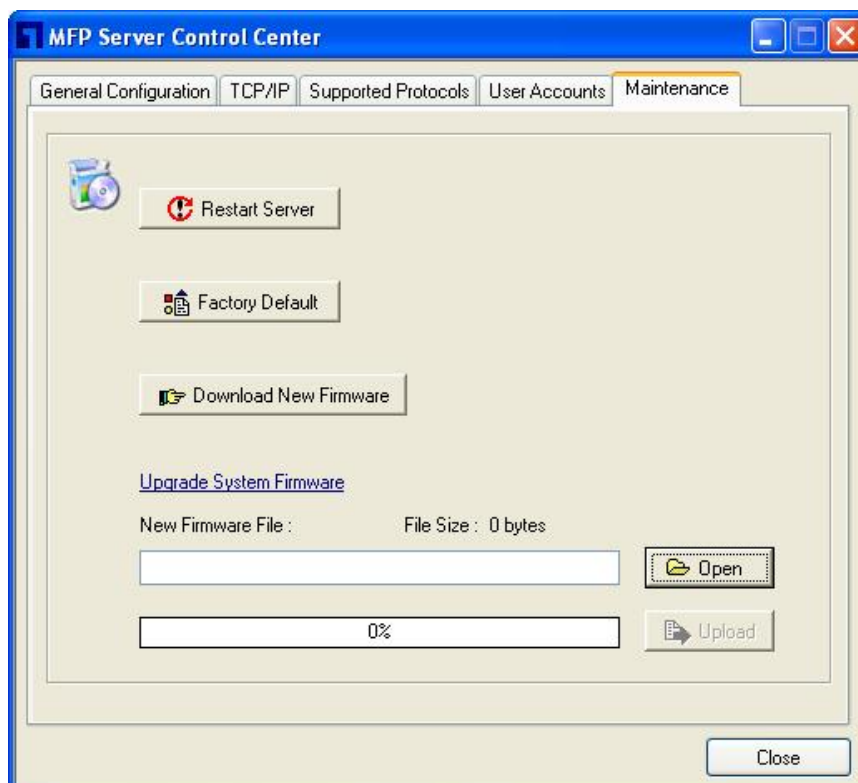

Procedure B: Using the Server's Web Pages

1. Power on the Server. Suppose that the Server is in DHCP mode.
2. Check the Server's IP address.
3. First, run Control Center. It will automatically search for Servers on the LAN. Then Servers' IP addresses will be shown in Control Center.
4. Run any Web browser, like Microsoft Internet Explorer. Go to "<http://Server's IP address>" or "<http://Server's Host Name>" to access the Server's home page.
5. Click **CONFIG** at the top of the menu.
6. Login the Server with Administrator (default: *admin*) and Password (default: *admin*).
7. Click **Maintenance**.
8. Click **Upgrade Firmware**.



9. Click **Browse** button to choose the file of new firmware.
10. Click **Upload** button to start firmware upgrade.
11. Wait for 15 seconds for system reboot.

Upgrade System Firmware

Upgrade LevelOne FUS-3100 Firmware

New Firmware File

8. Restore Factory Defaults

User may restore the factory default parameters by one of the following methods.

Using the Control Center Utility

1. Start the Control Center.
2. If the tool finds Servers in your local area network, then you have to select a Server from the Server List.
3. Double click the highlight list and enter the Server's administrator (default: *admin*) and password (default: *admin*).
4. After you have logged in successfully, from the Server menu, select **Maintenance**. The **Maintenance** dialog appears.
5. Click **Factory Default**.

Using the Server's Web Pages

1. Go to the Server's web page and click **CONFIG**
2. Enter administrator (default: *admin*) and password (default: *admin*).
3. Click **Maintenance**.



4. Click **Factory Default**.

Load the Factory Default?

This server will load the factory default and then restart!

Yes

No

5. Click **Yes** to confirm

Using Init Button

Plug in the power adaptor while pressing the Init button until LED indicators of Power and USB blinks. After that, plug off the power adaptor and then plug in the power adapter again to restart the Server. Finally, the Server will operate using the Factory Default values.

Default Parameters List

Host Information

- Server Name: **FUS-3100 / FPS-3003 / WUS-3200**
- Workgroup : **WORKGROUP**
- Description (Optional) **LevelOne FUS-3100 / FPS-3003 / WUS-3200 MFP Server**
- Code Page of File Server : **Western European**

TCP/IP

- Automatically get IP by DHCP: **Enabled**
 - Manual DNS: **None (Disabled)**.
- Static IP: **Disabled**
 - IP Address: **192.168.1.100**
 - Subnet Mask: **255.255.255.0**
 - Default Gateway: **none**
 - DNS Server: **none**

Supported Protocols

- SMB/CIFS Print/File Server: **Enabled**
 - Internet Access: **Disabled**

- Server Authentication: Disabled
- FTP Server: Enabled
 - FTP Port: 21
 - Set Maximum Session Number: 5 (Enabled)
 - Passive Mode: Enabled
 - Server Authentication: Enabled
 - Allow Anonymous Login: Disabled

User Accounts

- Administrator: admin
- Password: admin

9. The Init Button

The Init button is used for the maintenance: Plugging in the power adapter while pressing the Init button until USB indicators blink alternately. After that, the Server will do the following tasks:

- A. Reset the Server to factory default, which will restore most of the parameters and settings to factory default values,
- B. Perform a TFTP server. You can upgrade new firmware using the “Image Burner” utility.



Note

After performing the tasks mentioned above, you have to plug off the power adaptor and then plug in the power adaptor to restart the Server.

10. Troubleshooting

This chapter provides useful information to help you resolve difficulties that you may experience with your Server. Fault symptoms, possible causes, and remedial actions are provided within a quick reference table. This Server's USB ports only support MFPs, printers, scanners, and mass storage.

LED Indicators

Indicators	Color/Behavior	Description
Power	Green	Power On
	Not lit	Power off/System error
Link	Green	Network connected
	Not Lit	No physical connection to network
Status/ACT	Green blinking	Activity on network
	Not lit	No activity on network
USB1 & USB2	Green	USB device connected
	Green blinking	Connected USB device not supported
	Not lit	No physical connection to USB device

If Auto-Connect does not work

Please try Manual-Connect to the MFP via Control Center utility if Auto-Connect not work properly.

Firewall

If firewall software has been installed in the PC, it may block the communication between the PC and the MFP server so that the MFP server can not work properly. To solve this problem, either disable the firewall or configure the firewall to allow the following TCP and UDP ports:

7305, 7309, 20005, 30201, 30202, 30203